

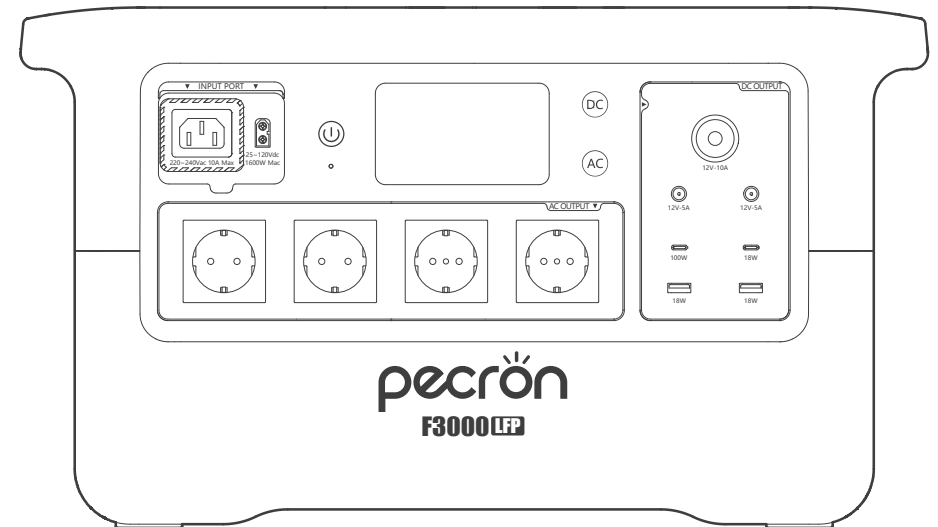

USER MANUAL

F3000 LFP



Follow PECRON's official account for more information and services.



NEED HELP? WE'RE HERE FOR YOU!

Website: <https://eu.pecron.com>

Customer Support: de@pecron.com / eu@pecron.com

PLEASE NOTE YOUR ORDER NUMBER AND PLATFORM OF PURCHASE,
SO WE CAN QUICKLY HELP YOU CHECK THE ORDER INFO AND SOLVE IT.

PECRON THANK YOU FOR YOUR SUPPORT AND COOPERATION!

Contact Us:

<https://eu.pecron.com>

F3000 LFP-EU-V1.2

USER MANUAL (ENGLISH)	P01-P18
BENUTZERHANDBUCH (DEUTSCH)	P19-P36
GUÍA DEL USUARIO(ESPAÑOL)	P37-P54
GUIDE DE L'UTILISATEUR (FRANÇAIS)	P55-P72
GUIDA PER L'UTENTE (ITALIANO)	P73-P90

DESCRIPTION OF SYMBOLS

⚠ Important Notes

💡 Tips for operation and use

FUNCTION INTRODUCTION

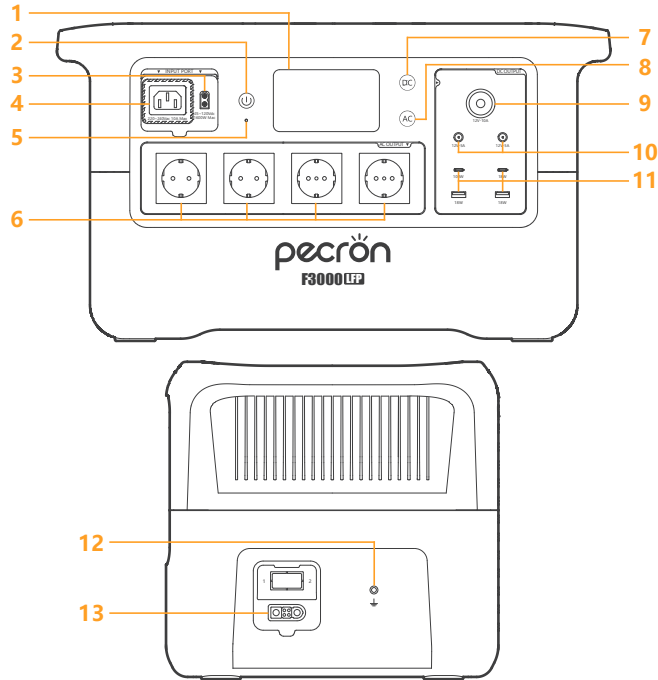

Product appearance and structure may vary by country/region; refer to the physical product.

- | | |
|------------------------------|----------------------------|
| 1 LCD Display | 8 AC 220V~240V Switch |
| 2 Main Switch | 9 DC Auxiliary Output |
| 3 DC 25V~120V Charging Port | 10 DC 5525 Output |
| 4 AC 220V~240V Charging Port | 11 USB-A / USB-C Ports |
| 5 Breathing Light | 12 External Grounding Port |
| 6 AC 220V~240V Output | 13 Battery Expansion Port |
| 7 DC 12V / USB Switch | |

SPECIFICATIONS

GENERAL INFO

Model	F3000 LFP
Capacity	3072Wh(51.2V60Ah)
Net Weight	Around 28.7kg / Around 63.3lb
Dimension	L489*W295*H282 mm / L19.3*W11.6*H11.1 in
Maximum Operating Altitude	3000m

OUTPUT SPECIFICATION

AC Output *4	Pure sine wave 220~240Vac Rated 3600W Max
USB-A *2	(5V,9V,12V,18W Max)*2
USB-C *2	(5V,9V,12V,18W Max)*1 (5V,9V,12V,20V,100W Max)*1
Cigar Port *1	DC 12V-10A
DC 5525 Output *2	DC 12V-5A

INPUT SPECIFICATION

AC INLET *1	220~240Vac, 50/60Hz, 2200W Max, 10A Max
XT60 *1	25Vdc~120Vdc, 1600W Max, 25A Max

EXTRA BATTERY PORT

XT120 *1	Cascade up to 2 battery packs
----------	-------------------------------

BATTERY SPECIFICATIONS

Cell Materials	LFP (LiFePO4)
Cycle Life	Maintains over 80% capacity after 3500 cycles

OPERATING TEMPERATURE

Supply Ambient Temperature	-10°C ~ 45°C / 14°F ~ 113°F
Charging Ambient Temperature	0°C ~ 45°C / 32°F ~ 113°F
Storage Ambient Temperature	-10°C ~ 45°C / 14°F ~ 113°F

DETAILS AND OPERATING INSTRUCTIONS OF THE DISPLAY

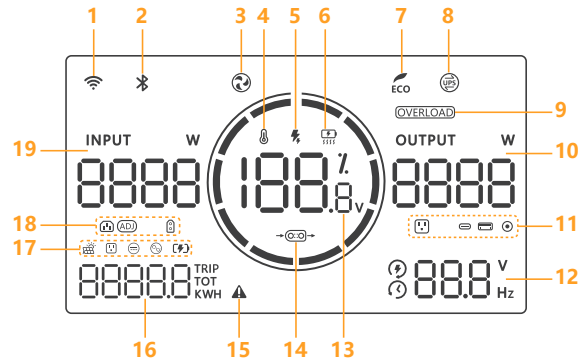

1		WIFI Connection	13		Battery Percentage Display
2		Bluetooth Connection	14		Input/Cascade Port Access /Output
3		Fan Working	15		Alarm Symbol
4		Temperature Alarm	16		Single Accumulated Power
5		Fast Charge			Total Accumulated Power
6		Battery heating has been turned on			Power Usage
7		ECO Mode	17		Solar Input (Total)
8		UPS Function			AC Input (Total)
9		Overload Alarm			DC Output (Total)
10		AC/DC Output			AC Output (Total)
11		AC Output Port			Battery Output (Total)
		USB-C Output Port	18		AC Input
		USB-A Output Port			AC Power Adjusted
		5521 Output Port			DC Input
12		Remaining Charging Time	19		AC/DC Input
		Remaining Usage Time			
		AC Output Voltage/Time /Frequency			



Blinking: The product has been reset and is in pairing mode.



Blinking: Overload protection triggered. Please disconnect some devices to reduce total power output. The alarm will automatically reset once power output returns to normal.

OPERATING INSTRUCTIONS

- Ⓛ 1: **Main On/Off Button:** Short press for 0.5s / long press to turn on, short press to turn off the screen when it power-on.
- Ⓛ 2: **Breathing Light:**
White Flashing: Device in operation or standby mode.
Solid Green: Device fully charged.
- Ⓛ DC 3: **DC Button:** Short press toggles the percentage voltage display when the power-on. Long press turns power on/off(beep).
- Ⓛ AC 4: **AC Button:** Short press toggles the percentage voltage display when the power-on. Long press turns power on/off(beep). / Same function as DC Button.

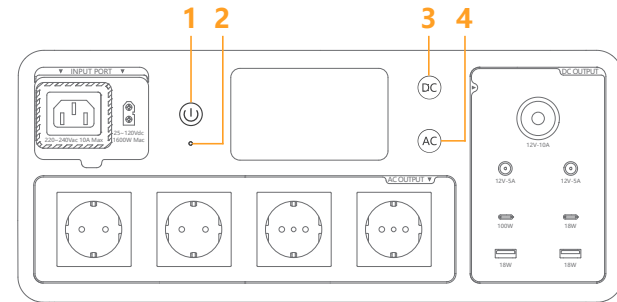

- Ⓛ + Ⓛ DC ECO MODE: Press & hold power + DC button for 3s to enter ECO mode when it power-on.
- Ⓛ Device Reset Into Pairing Mode: long press the on/off key for 5 seconds under power-off state, power on to reset the machine and join pairing mode (3 minutes). At this time the Bluetooth/WIFI icon is blinking.
- Ⓛ DC Access User Settings Interface: In the shutdown state, press and hold the DC key for 8 seconds to enter the user settings interface.

USER SETTINGS INTERFACE

Ⓚ Enter user settings interface: While powered off, press and hold the DC button for 8s to enter.

Ⓛ Press the power-off button to exit, or navigate to the last page to end and exit.

Short press DC button to switch setting, short press AC button to enter the next setting.

1: AC Charging Power Setting:
Rated power 20%~100%
(Factory default 100%).

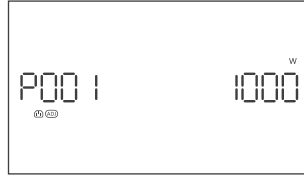

2: Auto-Shutdown Timer Without AC Output:
OFF/1H/2H/3H/4H
(Factory default OFF).

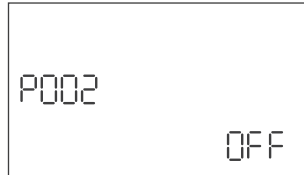

3: Button Brightness: OFF/L1/L2/L3
(Factory default L3)



4: Buzzer Sound: ON/OFF
(Factory default ON)



5: Anti-Touch Mode
(Factory default ON)

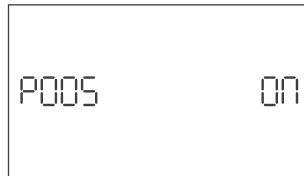

6: Auto-Dim LCD Screen Brightness:
ON/OFF
(Factory default ON)

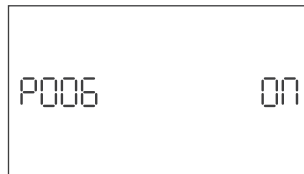

7: AC Output Frequency: 50Hz/60Hz



8: AC Output Voltage:
100V/110V/120V (LV Version)
220V/230V/240V (HV Version)



9: Parallel Mode Setting: ON/OFF
(Factory default OFF)
(LV version do not support)



USING THE STATISTICS INTERFACE

Standby: TOT = Total Power

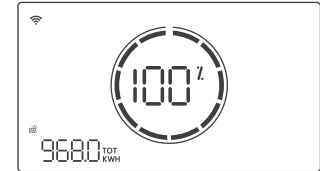

Operation: TRIP = Session Power/Since Startup

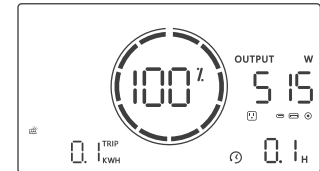

Standby: Short Press [DC] to display the input&output data.

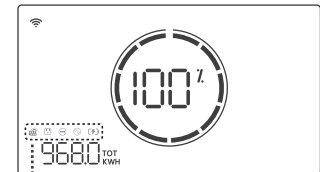

- Solar Input (Total)
- AC Input (Total)
- DC Output (Total)
- AC Output (Total)
- Battery Output (Total)

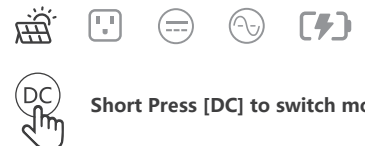

AC OUTPUT TO POWER THE DEVICE

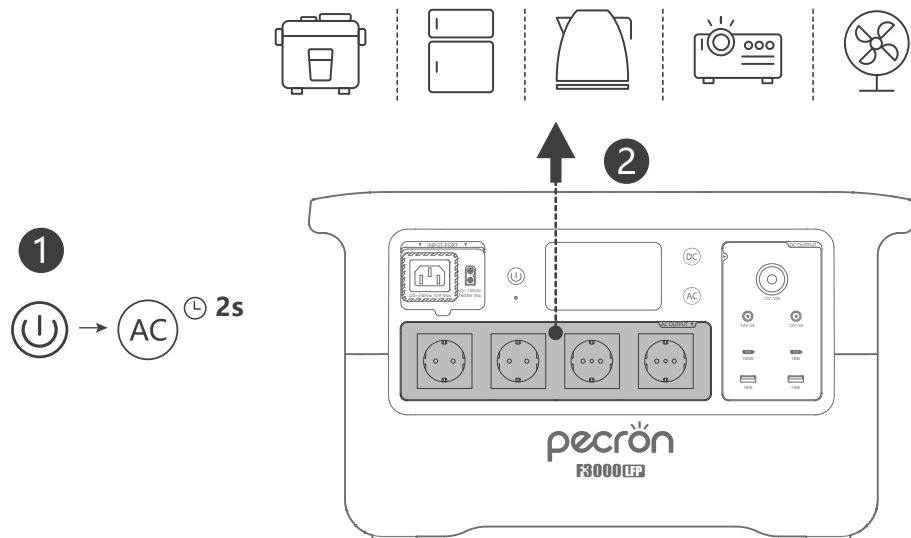

- 1: In the power-on state, press and hold the AC button to turn on the power output of the corresponding interface area.
- 2: Connect the device to the AC output socket of the product.

- 💡 1: A mild odor may be present during high-power output from internal electrical components, which is normal and will naturally dissipate with daily use.
- 2: When charging with AC inputs of different frequencies, the power supply will automatically switch to the frequency consistent with the input.

DC OUTPUT TO POWER THE DEVICE

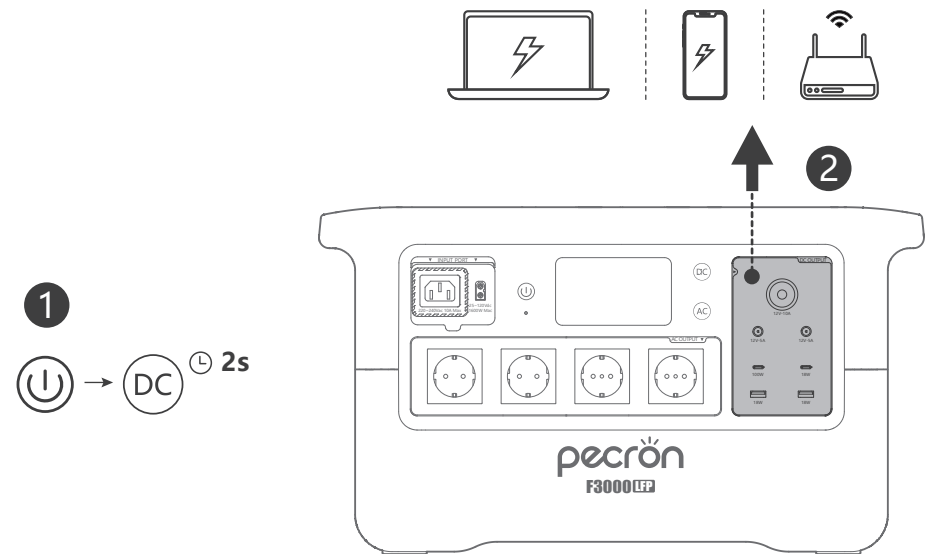

The portable power station can be used with other DC adapter cables (sold separately) to meet the charging needs of different types of devices through the DC output port.

USING AC CHARGING

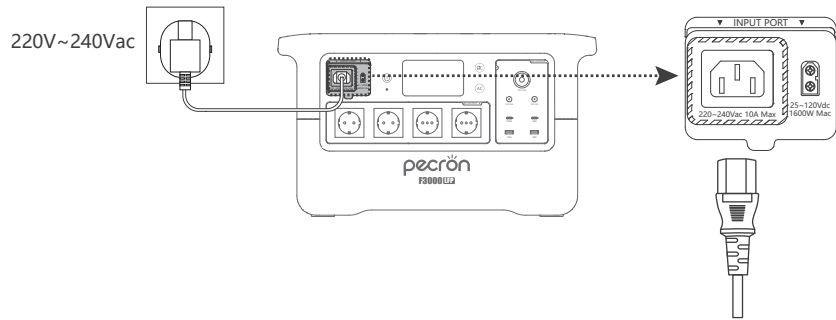

- 1: Please disconnect the mains power after charging is complete.
- 2: To extend the battery core life and improve the user experience, please avoid discharging the battery to an excessive level, which may damage the battery cores.
- 3: During charging, if the battery core temperature is too high or too low, the temperature alarm icon on the screen will flash. To ensure battery core life and safety, the charging power will decrease, which is a normal phenomenon.

UPS FUNCTION

F3000 LFP supports UPS functionality. It provides nearly instantaneous (within 8 to 20ms) protection for loads (such as computers) against unexpected main power interruptions. In UPS mode, the power supply supports automatic restoration of AC output. If there is a power outage and the power supply is depleted, when mains power is restored, the power supply can automatically turn on AC output to continue powering the electrical equipment.

This UPS function only support protection for loads under 3600W, we recommend that you only connect one device at a time to avoid overload and thus result in protection failure. PECRON is not responsible for any devices damage or loss of data resulting from failing to follow the instructions.

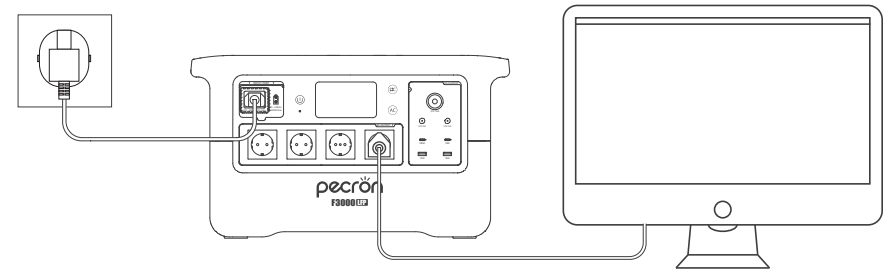

- 1: Not suitable for specific applications requiring transmission times below 8ms, such as servers and workstations, as it may cause abnormal operation of the equipment or data loss.
- 2: This feature is not supported in some regions. Please refer to local laws and regulations for details.

USING SOLAR PANELS CHARGING

Follow these steps

1: Unfold the solar panel and secure it using the bracket.

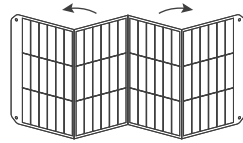

2: Adjust the bracket to change the angle of the solar panel to ensure it is directly aligned with the sunlight.

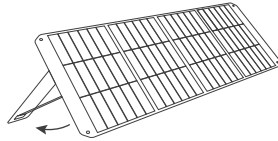

3: To improve solar charging efficiency, try to let sunlight vertically hit the solar panel and ensure there are no obstructions.

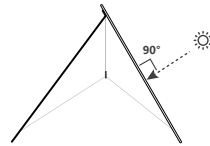

4: XT60 interface supports input voltage range of 25Vdc~120Vdc, maximum input power of 1600W, maximum current of 25A. When wired in series, the actual input voltage is the sum of all the connected solar panels, the total solar panels open-circuit voltage (Voc) must be less than 120V, and the operating voltage (Vmp) must be greater than 25V.

When wiring in parallel: the total solar current (Imp) should be close to the maximum input current (Imax) of the product interface.

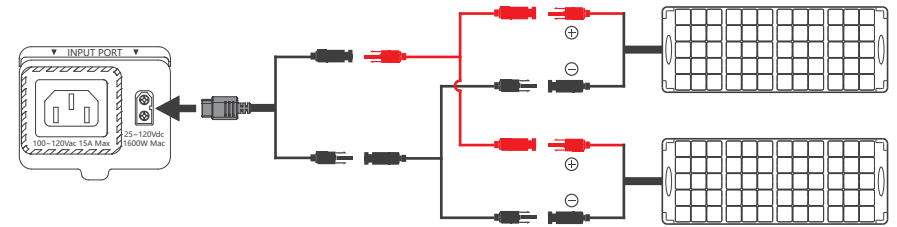
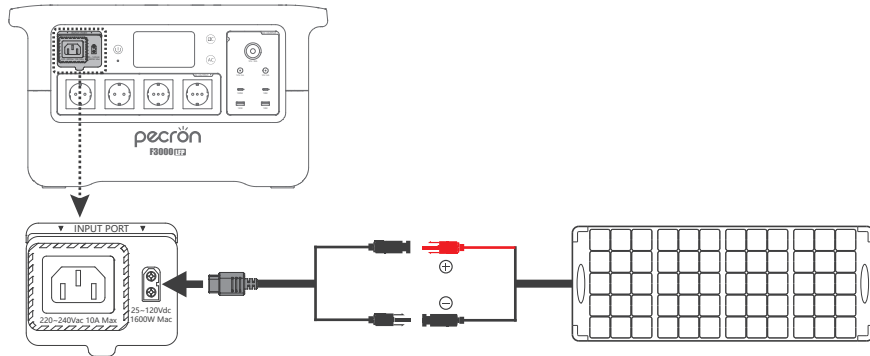

This parallel charging cable sold separately

- 1: Do not mix different types of solar panels, as it may damage the unit.
- 2: PECRON solar panels are recommended to avoid damage to the adapter module and power supply.
- 3: When using solar charging, pay attention to avoid direct sunlight on the power supply and adapter module to prevent overheating and damage.
- 4: Be sure to clean the debris on the surface of the solar panel in time. Partial shading on the solar panel will affect power generation efficiency.
- 5: Regularly clean the surface of the solar panel with a soft dry cloth dipped in water.

APP FUNCTION

You can connect to this product via the PECRON APP to view information, control the device, and make personalized settings.

Press and hold the power button for 5s while the device is off to reset the machine and enter pairing mode (for 3 minutes), at which point the Bluetooth/WIFI icon will flash.

iPhone users can search for PECRON in the Apple Store to download and use.

Android users can search for PECRON on Google Play to download and use.



⚠ Wi-Fi 2.4GHz is required for app connection.

BATTERY EXPANSION PORT FUNCTION

Up to two 48V battery pack can be cascaded through the cascade cable using the XT120 socket on the right hand side of the machine.

Do not use non-PECRON battery pack, as it may damage the power supply!

Notes about cascade:

Cascading will be faster if there is only 10% difference between the main power station and the expansion battery pack.

Battery expansion port (XT120) can output battery voltage (44V~58V) up to 40A through PECRON special inducer cable.

PACKING LIST

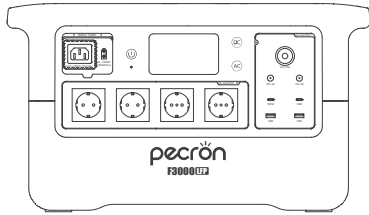

PECRON F3000 LFP *1

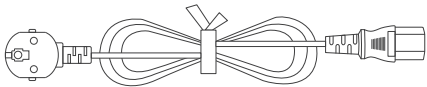

AC Cable *1

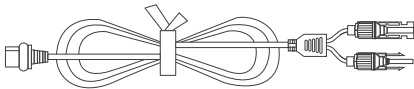

Single port XT60 to
MC4 solar charging cable *1



Accessory bag * 1

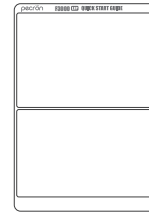

Quick Start Guide *1

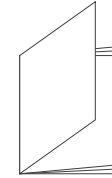

User Instruction *1

PRODUCT OPTIONAL ACCESSORIES

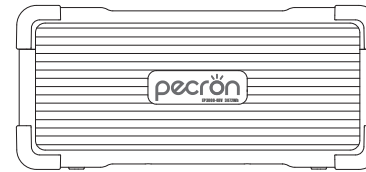

PECRON EP3000-48V

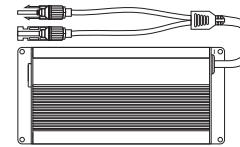

PECRON 500W
Smart Car Charger

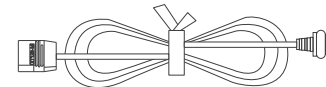

PECRON XT120 Induction Output Cable



More accessories can be
found in PECRON official website

FAULT RESOLUTION

Output overload alarm interface:

OVERLOAD flashing
Buzzer alarm 2 times

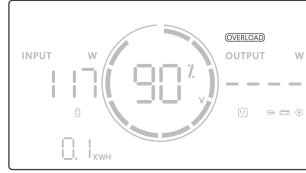

Battery temperature alarm interface:

Temperature symbol flashing
Buzzer alarm 3 times

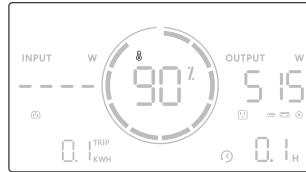

Other alarm interfaces: Exclamation mark flashes

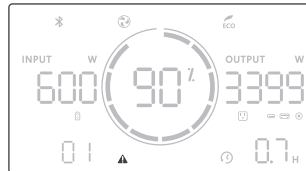

ALARM ITEMS

02	Battery pack undervoltage
03	Battery discharge overcurrent
04	Battery charge overcurrent
05	Battery short circuit
06	Battery disconnection
07	Battery low voltage, charging prohibited
08	Low charging temperature
09	High charging temperature
10	Low discharging temperature
11	High discharging temperature
12	Charging tube abnormality during discharging
20	Inverter overload
21	Inverter overtemperature
22	Busbar overvoltage/undervoltage
35	DC charging over-temperature

40 DC output short-circuit and overload

41 DC output overvoltage

42 DC output overcurrent

43 DC output over-temperature

51 Battery pack undervoltage

52 Battery pack discharge overcurrent

53 Battery pack charging overcurrent

54 Battery pack short circuit

55 Battery pack disconnection

57 Low temperature during the battery pack charging

58 High temperature during the battery pack charging

59 Low temperature during the battery pack discharge

60 High temperature during the battery pack discharge

FAQS

1: What kind of battery is used in F3000 LFP? How long it can last?

F3000 LFP utilizes high quality UL certified automotive LiFePO4 battery, it can retain 80% of its original capacity at 3500 complete charge cycles.

2: What devices can F3000 LFP power?

Please note that the AC output port can only charge or power devices that operate at less than 3600W. DC output port can only charge or power that operate at less than 12V-10A.

3: Can the F3000 LFP be used as UPS?

F3000 LFP supports UPS function with an automatic switchover time of 8~20ms.

4: How to calculate the F3000 LFP running time?

To estimate the operation time of the F3000 LFP, consider the load you're applying:

Operation time = Battery Capacity (Wh) x DoD x n ÷ (Load Power + F3000 LFP Self-con-sumption)

Note: DoD is the depth of discharge. n is the conversion efficiency of the inverter, which is typically over 93% for the F3000 LFP. The self-consumption power of the F3000 LFP is approximately 30W.

Operation time = 3072Wh x 95% x 93% ÷ (40W + 30W) ≈ 39 hours.

Please keep in mind that the estimated operation time provided is for reference purposes and may vary based on actual usage conditions. Factors such as low temperature and excessive loads can significantly affect the battery capacity, leading to a reduction in the average operation time.

5: Can the F3000 LFP be charged while discharging?

Yes, it can be charged and discharged at the same time. Under the non-UPS state, if uninterrupted use is required, the average power of charging must be greater than the average power of electricity, otherwise the battery will eventually run out and shut down.

6: Does F3000 LFP have built-in MPPT charge controller?

Yes, there is one independent built-in MPPT controller; "XT60" port supports 25~120V (Max 1600W) PV input.

7: Other issues to be noted.

Pay attention to the point that the product is without waterproof function and prevent water getting into it.

Pay attention to ventilation and heat dissipation when using, and keep good ventilation at the air inlet and outlet of the product.

Do not use the product in special occasions (under the mine, gas station, etc.)

MAINTENANCE AND UPKEEP/CARE

- 1: Store the device in an environment between -10°C (14°F) and 45°C (113°F). The recommended temperature range is approximately 0°C (32°F) to 30°C (86°F) to maintain the battery's health.
- 2: Store the product in a dry, cool, well-ventilated, and safe area to reduce the risk of drops.
- 3: Keep the device away from water sources, heat sources, strong magnetic fields, corrosive gas environments, and any flammable or explosive materials.
- 4: Fully charge the device at least once every two months. Prolonged partial charging may lead to inaccurate battery reading and degraded battery consistency.
- 5: For long-term storage, charge and discharge the product once every three months (fully charge, then discharge to 60% for storage) to maintain battery health.
- 6: Do not leave the device uncharged or unused for more than six months; otherwise, the warranty will be void.
- 7: If the power port is dirty, wipe it clean with a dry cloth. Do not use alcohol or other flammable agents to clean.

DISCLAIMER

Please read the user manual thoroughly before using this product, and keep this manual in a safe place for future reference. Failure to follow the instructions for proper set up, use, and care for the device can increase the risk of serious personal injury, death, or property damage. Once you use this device, you are deemed to have understood, recognized and accepted all terms and contents of this document. The user shall be responsible for his own actions and all consequences arising from failure to use the device in accordance with the "User Manual", or as authorized in PECRON's current product literature.

In compliance with laws and regulations, PECRON reserves all rights for final explanation, and to change these terms and conditions at any time without prior notice. In the event that any revisions are made, the revised terms and conditions shall be posted on our website immediately, please visit our website to inform yourself of any changes.

WARNING

- 1: Do not place the device near heat source, such as a fire or a heating furnace.
- 2: Do not immerse in any liquid, or expose the unit to rain or wet conditions.
- 3: Do not use the battery in a strong static electricity or electromagnetic environment.
- 4: Do not disassemble or puncture the product with sharp objects in any way.
- 5: Short circuits can be caused by: vermin or pests chewing through wires; water or other fluids coming into contact with electrical wiring.
- 6: It's prohibited to be used as car jump starter, only can be used to charge the car battery.
- 7: Do not use accessories or parts other than those provided by PECRON. Please visit our website www.pecron.com or reach our support team for a complete list of accessories and parts.

- 8: When using this product, please strictly follow the ambient temperature for use in the user manual. If the temperature is too high, the battery can potentially result in self-combustion and will burst into flames, which can cause widespread damage. If the temperature is too low, the performance of the battery will be seriously degraded, and it may even fail to meet the normal use requirements.
- 9: Do not stack heavy objects on this product.
- 10: Do not block the air vents during use, or leave the device in a non-ventilated or dusty space.
- 11: Please avoid impacts, fall off, and violent vibration. Please turn off the device immediately and stop using it in the event of major exterior impact. Please fasten the unit firmly during transportation to avoid vibration and impact.
- 12: In the event of immersing the device into the water accidentally, please place the unit in a safe open area and keep away from the unit until it is completely dry. The dried unit should not be reused and should be disposed of properly according to the local regulation. If the device catches fire, use the fire extinguishing equipment in the following recommended order: water or mist, sand, fire blanket, dry chemical, carbon dioxide fire extinguisher.
- 13: Please wipe it with a dry cloth to clean the surface of the device.
- 14: Please place this device with care to prevent the product from being damaged due to fall off. If the product is damaged due to fall off, please turn off the unit immediately and place it in an open area, keep away from combustibles and crowds, and dispose of in accordance with local laws and regulations.
- 15: Please store this device in a place out of reach of children and pets.

DISPOSAL

- 1: When conditions permit, please be sure to completely discharge the battery of this product, and then put the product in the designated battery recycling box. This product contains batteries. Batteries are dangerous chemicals and are strictly prohibited from being disposed of in ordinary trash. For details, please follow local laws and regulations on battery recycling and disposal.
- 2: If the battery cannot be completely discharged due to the failure of the product itself, please do not dispose of the battery directly in the battery recycling box, and contact a professional battery recycling company for further disposal.
- 3: The battery will not be able to start after being over-discharged, please dispose of it according to the principle of disposal.

EXCLUSIONS

PECRON's warranty does not apply to:
Misused, abused, modified, damaged by accident, or used for anything other than normal consumer use as authorized in PECRON's current product literature.

SYMBOLERKLÄRUNG

⚠ Wichtige Hinweise

💡 Bedienungs- und Nutzungshinweise

PRODUKTÜBERSICHT

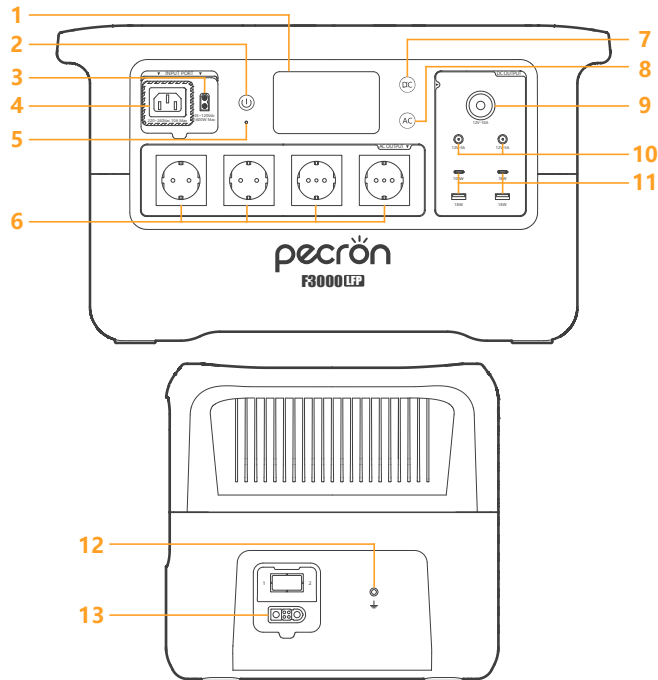

Abweichungen zwischen Abbildung und tatsächlicher Produktstruktur sind je nach Land/Region möglich. Maßgeblich ist das gelieferte Produkt.

- | | |
|------------------------------|-----------------------------------|
| 1 LCD-Display | 8 AC 220V~240V Schalter |
| 2 Hauptschalter | 9 DC Zigarettenanzünder |
| 3 DC 25V~120V Ladeanschluss | 10 DC 5525 Ausgang |
| 4 AC 220V~240V Ladeanschluss | 11 USB-A/USB-C Anschluss |
| 5 Status-LED (Atmeffekt) | 12 Externer Erdungsanschluss |
| 6 AC 220V~240V Ausgang | 13 Batterie-Erweiterungsanschluss |
| 7 DC 12V/USB-Schalter | |

TECHNISCHE SPEZIFIKATIONEN

ALLGEMEINE INFORMATIONEN

Modellbezeichnung	F3000 LFP
Kapazität	3072Wh(51.2V60Ah)
Nettogewicht	ca. 28,7 kg / ca. 63,3 lb
Abmessungen	L489*W295*H282 mm / L19.3*W11.6*H11.1 in
Maximale Betriebshöhe	3000m

AUSGANGSSPEZIFIKATIONEN

AC-Ausgang*4	Reine Sinuswelle 220~240Vac Max. Nennleistung 3600W
USB-A-Ausgang*2	(5V,9V,12V,Max. 18W)*2
USB-C-Ausgang*2	(5V,9V,12V,Max. 18W)*1 (5V,9V,12V,20V,Max. 100W)*1
Zigarettenanzünder-Ausgang*1	DC 12V-10A
DC 5525-Ausgang*2	DC 12V-5A

EINGANGSSPEZIFIKATIONEN

AC-Eingang*1	220~240Vac, 50/60Hz, Max. 2200W, Max. 10A
XT60*1	25Vdc~120Vdc, Max. 1600W, Max. 25A

KASKADIERUNGSFUNKTION

XT120*1	Max. 2 Zusatzbatterien kaskadierbar
---------	-------------------------------------

BATTERIESPEZIFIKATIONEN

Zellchemie	LFP (Lithium-Eisenphosphat)
Zykluslebensdauer	≥80% Kapazität nach 3.500 Ladezyklen

BETRIEBSTEMPERATUR

Umgebungstemperatur (Betrieb)	-10°C ~ 45°C / 14°F ~ 113°F
Umgebungstemperatur (Ladung)	0°C ~ 45°C / 32°F ~ 113°F
Lagertemperatur	-10°C ~ 45°C / 14°F ~ 113°F

DISPLAY-ANZEIGEN UND BEDIENUNGSHINWEISE

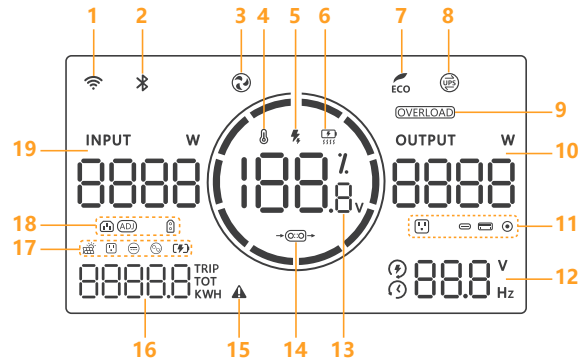

- | | | | | | |
|----|-----------------|--|----|-------------|--|
| 1 | | WLAN-Verbindung | 13 | | Ladestandsanzeige (in Prozent) |
| 2 | | Bluetooth-Verbindung | 14 | | Eingang/Kaskadierungsanschluss /Ausgang |
| 3 | | Lüfter | 15 | | Warnsymbol |
| 4 | | Temperaturalarm | 16 | TRIP | Einzelner Energieverbrauch |
| 5 | | Schnellladung | | TOT | Gesamtenergieverbrauch |
| 6 | | Batterieheizung aktiv | 17 | | Angezeigte Solar-Ladeleistung (kumuliert) |
| 7 | | ECO-Modus | | | Angezeigte AC-Ladeleistung (kumuliert) |
| 8 | | USV (Unterbrechungsfreie Stromversorgung) | | | Angezeigte DC-Ausgangsleistung (kumuliert) |
| 9 | OVERLOAD | Überlastalarm | | | Angezeigte AC-Ausgangsleistung (kumuliert) |
| 10 | | AC/DC-Ausgang | | | Angezeigte Batterie-Ausgangsleistung (kumuliert) |
| 11 | | AC-Ausgangsanschluss | 18 | | AC-Eingang |
| | | USB-C-Ausgangsanschluss | | | AC-Leistung angepasst |
| | | USB-A-Ausgangsanschluss | | | DC-Eingang |
| 12 | | Verbleibende Ladezeit | 19 | | AC/DC-Eingang |
| | | Verbleibende Nutzungsdauer | | | |
| | | AC-Ausgangsspannung/Zeit/Frequenz | | | |
| | | Blinken: Das Gerät wurde zurückgesetzt und befindet sich im Pairing-Modus. | | | |
| | OVERLOAD | Blinken: Überlastschutz wurde ausgelöst. Bitte entfernen Sie einige angeschlossene Geräte, um die Gesamtleistung zu reduzieren. Der Alarm deaktiviert sich automatisch, sobald die Leistung wieder im Normalbereich liegt. | | | |

BEDIENUNGSANLEITUNG

- ⏻ **1: Hauptschalter** Kurzer Druck (0,5s): Einschalten / Langer Druck: Ausschalten.
Bei eingeschaltetem Zustand: Kurzer Druck deaktiviert Display.
- ⦿ **2: Status-LED** Weiß blinkend: Gerät in Betrieb oder Bereitschaftsmodus.
Grün leuchtend: Akku vollständig geladen.
- Ⓛ **3: DC-Taste** Bei eingeschaltetem Zustand: Kurzer Druck wechselt Spannungs-/Prozentanzeige.
Langer Druck aktiviert/deaktiviert DC (Bestätigungston ertönt).
- Ⓜ **4: AC-Taste** Bei eingeschaltetem Zustand: Kurzer Druck wechselt Spannungs-/Prozentanzeige.
Langer Druck aktiviert/deaktiviert AC (Bestätigungston ertönt).

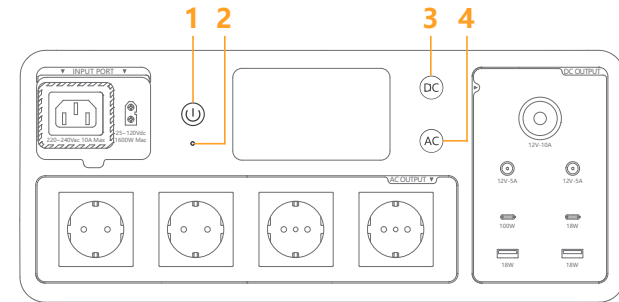

- ⏻ + Ⓛ **ECO-Modus:** Bei eingeschaltetem Zustand Hauptschalter + DC-Taste 3 Sekunden gedrückt halten.
- ⏻ **Gerätereset & Netzwerkmodus:** Bei ausgeschaltetem Zustand Hauptschalter 5 Sekunden halten - startet Reset und Pairing-Modus (3 Minuten), Bluetooth/WLAN-Symbol blinkt.
- Ⓛ **Benutzereinstellungen:** Bei ausgeschaltetem Zustand DC-Taste 8 Sekunden halten.

BENUTZEREINSTELLUNGSMENÜ

 Zugang zum Einstellungsmenü: Bei ausgeschaltetem Zustand DC-Taste 8 Sekunden gedrückt halten.

 Mit Einschalttaste beenden oder nach letzter Einstellungsseite automatisch verlassen.

Kurzer DC-Tastendruck: Einstellung wechseln. Kurzer AC-Tastendruck: Nächste Option.

1: AC-Ladeleistung: 20%~100% einstellbar
(Werksvorgabe: 100%)



2: Automatische Abschaltung bei Inaktivität:
OFF/1H/2H/3H/4H
(Werksvorgabe: OFF)

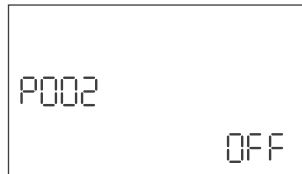

3: Tastenbeleuchtung: OFF/L1/L2/L3
(Werksvorgabe: L3)



4: Signalton: ON/OFF
(Werksvorgabe: ON)

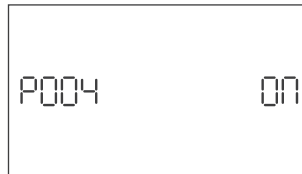

5: Tastensperre
(Werksvorgabe: ON)

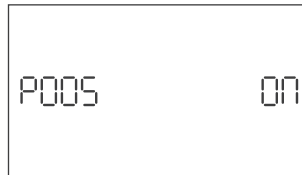

6: Automatische LCD-Helligkeitsreduzierung:
ON/OFF
(Werksvorgabe: ON)

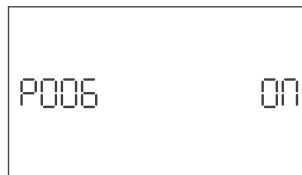

7: AC-Ausgangsfrequenz: 50Hz/60Hz



8: AC-Ausgangsspannung:
100V/110V/120V (LV-Version)
220V/230V/240V (HV-Version)



9: Parallelbetrieb-Modus: ON/OFF
(Werkstandard: OFF)
(LV-Version nicht unterstützt)

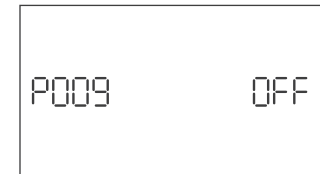

NUTZUNGSSTATISTIK-ANSICHT

Im Standby-Modus zeigt "TOT" die Gesamtleistung an.

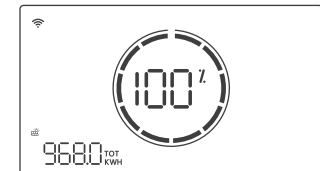

Im Betriebsmodus zeigt "TRIP" den Verbrauch seit dem Einschalten an.

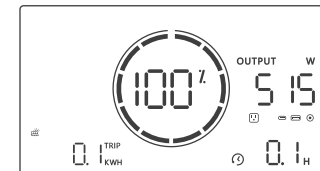

Im Standby-Modus: Kurzes Drücken der DC-Taste wechselt die Anzeige.

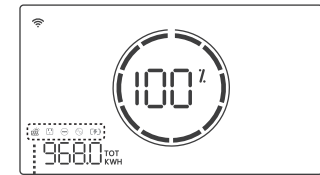

-  Angezeigte Solar-Ladeleistung (kumuliert)
-  Angezeigte AC-Ladeleistung (kumuliert)
-  Angezeigte DC-Ausgangsleistung (kumuliert)
-  Angezeigte AC-Ausgangsleistung (kumuliert)
-  Angezeigte Batterie-Ausgangsleistung (kumuliert)

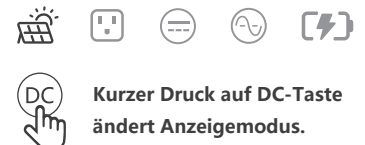

AC-AUSGANGSSTROMVERSORGUNG

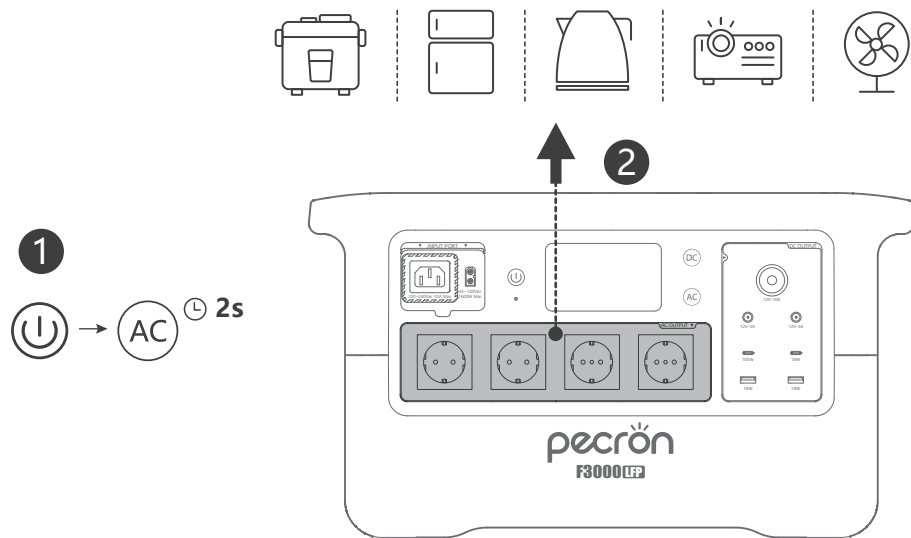

- 1: Bei eingeschaltetem Zustand AC-Taste lang drücken, um die Stromversorgung im entsprechenden Anschlussbereich zu aktivieren.
- 2: Gerät an die AC-Ausgangssteckdose des Produkts anschließen.

- ⚡ 1: Bei hoher Leistungsabgabe kann leichter Geruch auftreten - normaler Vorgang, der sich bei regelmäßiger Nutzung von selbst verliert.
- 2: Bei Ladung mit wechselnden AC-Eingangsfrequenzen schaltet die Stromversorgung automatisch auf die jeweilige Eingangsfrequenz um.

DC-AUSGANG ZUR STROMVERSORGUNG VON GERÄTEN

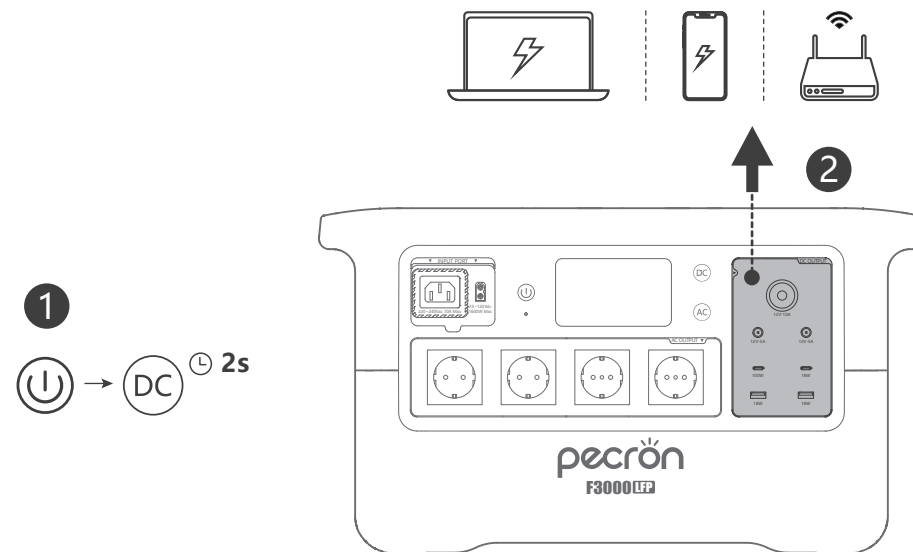

- Die Stromquelle kann mit anderen DC-Adapterkabeln (separat erhältlich) verwendet werden. Über den DC-Ausgangsanschluss können verschiedene Gerätetypen aufgeladen werden.

AUFLADEN ÜBER AC-NETZTEIL

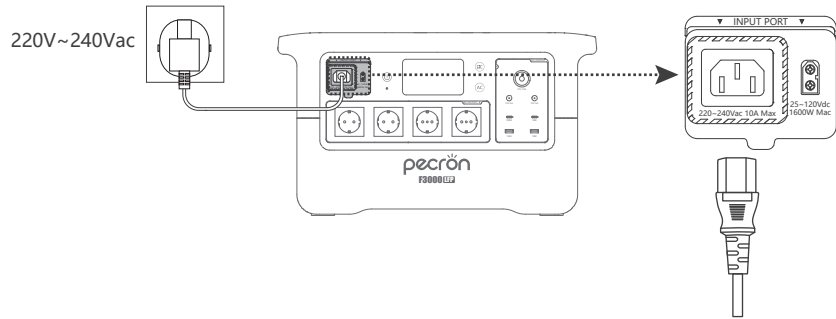

- 1: Nach dem Aufladen bitte die Verbindung zum Stromnetz trennen.
- 2: Um die Lebensdauer der Batteriezellen zu verlängern und das Nutzererlebnis zu verbessern, vermeiden Sie eine Tiefentladung der Batterie, die zu Zellschäden führen kann.
- 3: Während des Ladevorgangs blinkt bei zu hoher oder zu niedriger Zelltemperatur das Temperaturwarnsymbol auf dem Display. Zum Schutz der Batterie und Ihrer Sicherheit wird die Ladeleistung reduziert - dies ist ein normaler Vorgang.

UPS-FUNKTION

Der F3000 LFP unterstützt die UPS-Funktion. Er bietet nahezu sofortigen Schutz (innerhalb von 8 bis 20 ms) für angeschlossene Geräte (wie Computer) bei unerwarteten Stromausfällen. Im UPS-Modus stellt die Stromquelle automatisch die AC-Ausgabe wieder her. Bei Stromausfall und leerem Akku schaltet sie nach Wiederherstellung der Netzspannung automatisch die AC-Ausgabe wieder ein, um die Geräte weiter zu versorgen.

Diese UPS-Funktion unterstützt nur Lasten unter 3600W. Wir empfehlen, jeweils nur ein Gerät anzuschließen, um Überlastung zu vermeiden.

PECRON übernimmt keine Haftung für Geräteschäden oder Datenverlust, die durch nicht bestimmungsgemäße Verwendung entstehen.

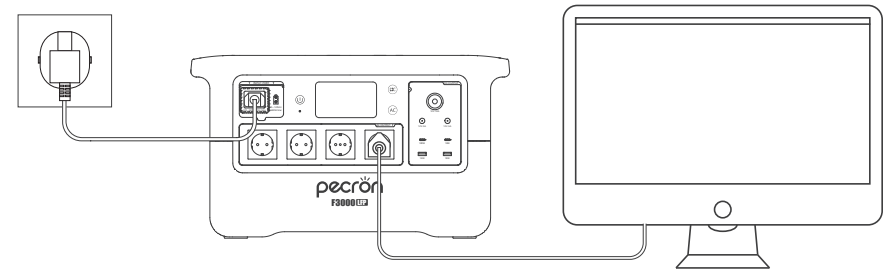

- 1: Nicht geeignet für Anwendungen, die Übertragungszeiten unter 8ms erfordern (z.B. Server und Workstations), da dies zu Funktionsstörungen oder Datenverlust führen kann.
- 2: In einigen Regionen ist diese Funktion nicht verfügbar. Bitte beachten Sie die lokalen Gesetze und Vorschriften.

AUFLADEN MIT SOLARMODULEN

Vorgehensweise:

1: Entfalten Sie das Solarmodul und befestigen Sie es mit dem Ständer.

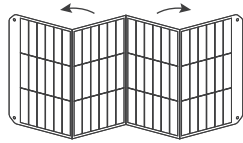

2: Stellen Sie den Neigungswinkel des Moduls durch Verstellung des Ständers so ein, dass es direkt zur Sonne ausgerichtet ist.

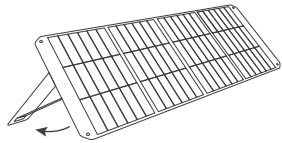

3: Für maximale Ladeeffizienz sollte das Sonnenlicht möglichst senkrecht auf das Modul treffen, ohne Abschattung.

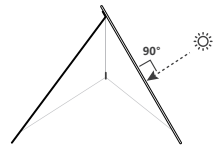

4: Der XT60-Anschluss unterstützt eine Eingangsspannung von 25Vdc bis 120Vdc, max. Eingangsleistung 1600W, max. Strom 25A. Bei Reihenschaltung addieren sich die Spannungen der Module. Die Leerlaufspannung (Voc) aller Module muss <120V, die Betriebsspannung (Vmp) >25V sein. Bei Parallelschaltung sollte der Gesamtstrom (Imp) dem max. Eingangsstrom (Imax) des Anschlusses entsprechen.

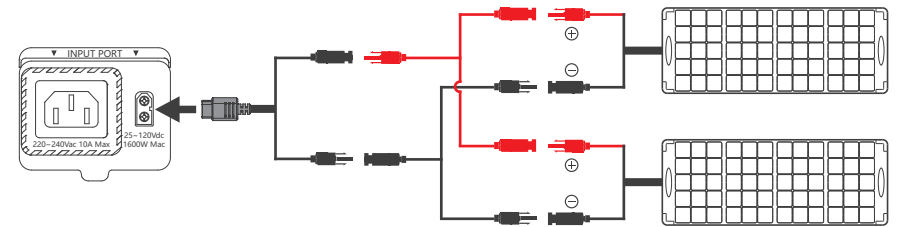
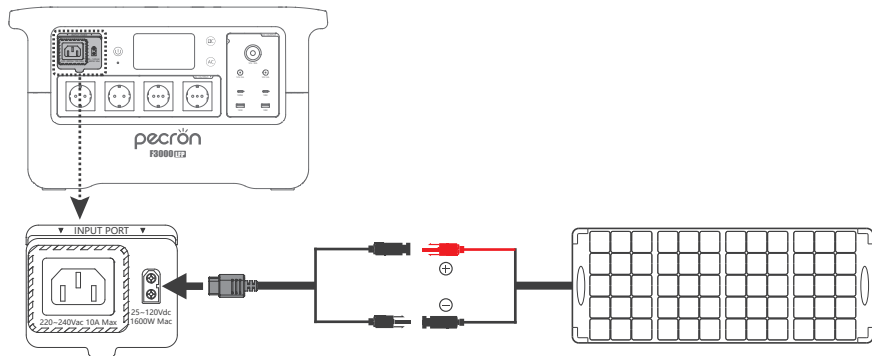

Parallelkabel sind separat erhältlich.

1: Verwenden Sie keine unterschiedlichen Solarmodul-Typen zusammen, da dies zu Geräteschäden führen kann.

2: Wir empfehlen die Verwendung von PECRON-Solarmodulen, um Schäden am Wandlermodul und Stromspeicher zu vermeiden.

⚠ 3: Achten Sie darauf, dass Stromspeicher und Wandlermodul während des Solarladens nicht direkter Sonneneinstrahlung ausgesetzt sind, um Überhitzungsschäden zu verhindern.

4: Reinigen Sie die Moduloberfläche regelmäßig von Verschmutzungen. Teilverschattungen beeinträchtigen die Energieausbeute.

5: Wischen Sie die Oberfläche der Solarmodule regelmäßig mit einem weichen, leicht angefeuchteten Tuch ab.

APP-FUNKTIONEN

Mit der PECRON APP können Sie dieses Produkt verbinden, Informationen abrufen, das Gerät steuern und persönliche Einstellungen vornehmen.

Halten Sie den Einschaltknopf im ausgeschalteten Zustand 5 Sekunden gedrückt, um das Gerät zurückzusetzen und in den Pairing-Modus zu versetzen (3 Minuten). Dabei blinkt das Bluetooth/WIFI-Symbol.

iPhone-Nutzer können die App im Apple Store unter "PECRON" suchen und herunterladen.

Android-Nutzer finden die App im Google Play Store durch Suche nach "PECRON".



⚠ Für die Verbindung der App muss Wi-Fi (2,4 GHz) verwendet werden!

FUNKTION DES BATTERIEERWEITERUNGSANSCHLUSSES

Über den XT120-Anschluss auf der rechten Geräteseite können maximal zwei 48V-Zusatzakkus mittels Kaskadierkabel verbunden werden.

Verwendung von nicht PECRON-zertifizierten Zusatzakku ist strengstens untersagt - dies kann zu Geräteschäden führen!

Hinweise zur Kaskadierung: Bei einer Ladungsdifferenz von $\leq 10\%$ zwischen Hauptgerät und Zusatzakku erfolgt die Kaskadierung schneller.

Der Batterieerweiterungsanschluss (XT120) kann mit PECRON-Spezialkabeln Batteriespannung (44V~58V) mit max. 40A ausgeben.

PRODUKT- UND ZUBEHÖRLISTE

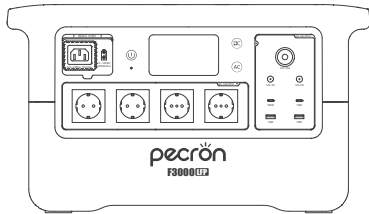

PECRON F3000 LFP *1

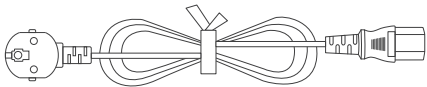

Netzkabel *1

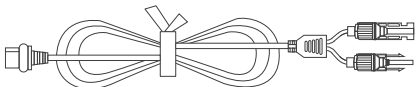

Solar-Ladekabel XT60 zu MC4 *1



Zubehörtasche *1

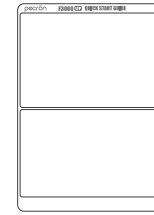

Kurzanleitung *1

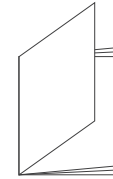

Benutzerhandbuch *1

OPTIONALE ZUBEHÖRTEILE

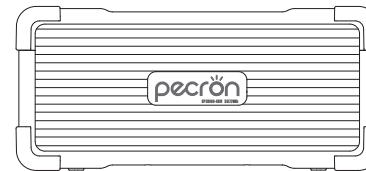

PECRON EP3000-48V

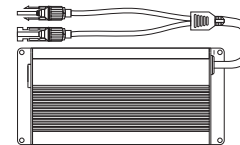

PECRON 500W
intelligentes Autoladegerät

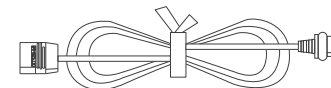

PECRON XT120 Ausgangskabel



Weitere Zubehörteile finden
Sie auf der PECRON-Website

FEHLERBEHEBUNG

Ausgangsüberlastungsalarm:
"OVERLOAD" blinkt.
Summer ertönt 2x

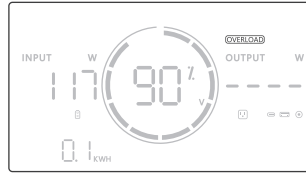

Batterietemperaturalarm:
Temperatursymbol blinkt.
Summer ertönt 3x

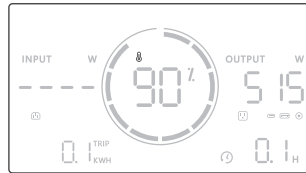

Sonstige Alarmmeldungen:
Ausrufezeichen blinkt

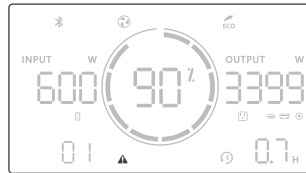

ALARMTYPEN

- 02 Batteriepack UnterSpannung
- 03 Batterie-Entladestrom überschritten
- 04 Batterie-Ladestrom überschritten
- 05 Batterie-Kurzschluss
- 06 Batterie-Unterbrechung
- 07 Ladesperre bei Batterie-Niederspannung
- 08 Lade-Temperatur zu niedrig
- 09 Lade-Temperatur zu hoch
- 10 Entlade-Temperatur zu niedrig
- 11 Entlade-Temperatur zu hoch
- 12 Ladeelektronik-Fehler während Entladung
- 20 Wechselrichter-Überlast
- 21 Wechselrichter-Übertemperatur
- 22 DC-Bus Über-/Unterspannung
- 35 DC-Lade-Übertemperatur

40 DC-Ausgang Kurzschluss/Überlast

41 DC-Ausgang Überspannung

42 DC-Ausgang Überstrom

43 DC-Ausgang Übertemperatur

51 Zusatzakku UnterSpannung

52 Zusatzakku-Entladestrom überschritten

53 Zusatzakku-Ladestrom überschritten

54 Zusatzakku-Kurzschluss

55 Zusatzakku-Unterbrechung

57 Zusatzakku Lade-Temperatur zu niedrig

58 Zusatzakku Lade-Temperatur zu hoch

59 Zusatzakku Entlade-Temperatur zu niedrig

60 Zusatzakku Entlade-Temperatur zu hoch

HÄUFIGE FRAGEN

1: Welche Zellentechnologie verwendet der F3000 LFP und wie lange ist seine Lebensdauer?

Der F3000 LFP verwendet hochwertige Automotive-LFP-Zellen (LiFePO4) mit UL-Zertifizierung. Nach 3.500 vollen Ladezyklen beträgt die Kapazität noch über 80%.

2: Für welche Geräte eignet sich der F3000 LFP?

Er versorgt AC-Geräte bis 3600W und DC-Geräte mit 12V/10A.

3: Verfügt der F3000 LFP über eine UPS-Funktion?

Ja, mit USV-Funktion (Umschaltzeit 8-20ms).

4: Wie berechnet man die Laufzeit des F3000 LFP?

Berechnungsformel: Laufzeit = Akkukapazität (Wh) x DoD x η ÷ (Lastleistung + Eigenverbrauch)

Hinweis: DoD = Entladetiefe. η = Wirkungsgrad (>93%). Eigenverbrauch \approx 30W.

Beispiel: $3072\text{Wh} \times 95\% \times 93\% \div (40\text{W} + 30\text{W}) \approx 39$ Std.

Hinweis: Die Laufzeit kann je nach Bedingungen variieren. Niedrige Temperaturen und Überlast reduzieren die Kapazität.

5: Kann der F3000 LFP gleichzeitig laden und entladen?

Ja. Im Nicht-USV-Betrieb muss die Ladeleistung die Entladeleistung übersteigen, sonst entlädt sich der Akku.

6: Hat der F3000 LFP einen MPPT-Laderegler?

Ja, mit integriertem MPPT-Regler (25-120V, max. 1600W über XT60-Anschluss).

7: Weitere Hinweise

Nicht wasserdicht - vor Feuchtigkeit schützen!

Ausreichende Belüftung gewährleisten!

Nicht für Bergwerke/Tankstellen etc. geeignet.

WARTUNG UND PFLEGE

- 1: Lagern Sie das Gerät bei -10°C bis 45°C (optimal 0°C bis 30°C), um die Batteriegesundheit zu erhalten.
- 2: An einem trockenen, kühlen, gut belüfteten und sicheren Ort aufbewahren, um Sturzrisiken zu minimieren.
- 3: Fernhalten von Wasser, Hitzequellen, starken Magnetfeldern, korrosiven Gasen und brennbaren Substanzen.
- 4: Mindestens alle 2 Monate vollständig aufladen, um Messungenauigkeiten und Batterieungleichgewichte zu vermeiden.
- 5: Bei Langzeitlagerung alle 3 Monate einen Lade-/Entladezyklus durchführen (voll laden, dann auf 60% entladen).
- 6: Nicht länger als 6 Monate ungenutzt lassen - dies führt zum Garantieverlust.
- 7: Verschmutzte Anschlüsse nur mit trockenem Tuch reinigen.
Keine brennbaren Reinigungsmittel verwenden!

HAFTUNGSAUSSCHLUSS

Vor Gebrauch bitte die Bedienungsanleitung lesen, um eine korrekte Anwendung bei vollständigem Verständnis zu gewährleisten. Bewahren Sie die Anleitung nach dem Lesen sicher für spätere Referenz auf. Bei unsachgemäßer Handhabung können schwere Verletzungen, Produktschäden oder Sachschäden entstehen. Durch die Nutzung des Produkts bestätigen Sie, alle Bedingungen vollständig verstanden und akzeptiert zu haben. Der Nutzer verpflichtet sich, für alle Konsequenzen seines Handelns selbst verantwortlich zu sein. Unser Unternehmen haftet nicht für Schäden, die durch nicht bestimmungsgemäße Verwendung entstehen.

Gemäß geltendem Recht behält sich unser Unternehmen das finale Interpretationsrecht aller Produktdokumente vor. Änderungen oder Produkteinstellungen werden ohne Ankündigung vorgenommen. Aktuelle Informationen finden Sie auf der PECRON-Website.

GEBRAUCHSHINWEISE

- 1: Bei Betrieb strikt von Hitzequellen wie offenen Flammen oder Heizgeräten fernhalten.
- 2: Jeden Kontakt mit Flüssigkeiten vermeiden. Nicht eintauchen oder benetzen.
Kein Einsatz bei Regen oder in feuchter Umgebung.
- 3: Verboten in stark elektrostatischen oder magnetischen Umgebungen.
- 4: Jegliche Demontage oder Beschädigung mit spitzen Gegenständen ist untersagt.
- 5: Kurzschlüsse durch Drähte oder Metallgegenstände strikt vermeiden.
- 6: Nicht für Starthilfe geeignet - nur zur Batterienachladung verwenden.
- 7: Nur Originalzubehör verwenden. Ersatzteile ausschließlich über autorisierte PECRON-Vertriebskanäle beziehen.
- 8: Betrieb nur in den spezifizierten Temperaturbereichen. Überhitzung kann zu Bränden/Explosionen führen, Kälte reduziert die Leistung erheblich.
- 9: Keine Gegenstände auf dem Gerät stapeln.

- 10: Lüfter nicht blockieren und staubige/schlecht belüftete Räume vermeiden.
- 11: Vor Stößen, Stürzen und Vibrationen schützen. Bei starken Beschädigungen sofort abschalten.
Beim Transport sichern.
- 12: Bei Wasserkontakt in sicherem Abstand trocknen lassen. Getrocknete Geräte nicht wiederverwenden - fachgerecht entsorgen. Bei Brand in dieser Reihenfolge löschen:
Wasser/Nebel, Sand, Löschdecke, Pulver, CO₂-Löscher.
- 13: Verschmutzte Anschlüsse nur mit trockenem Tuch reinigen.
- 14: Standsicher platzieren. Bei Sturzbeschädigung sofort deaktivieren, Batterie in sicherem Abstand lagern und gemäß lokalen Vorschriften entsorgen.
- 15: Außerhalb der Reichweite von Kindern und Haustieren aufbewahren.

ENTSORGUNG

- 1: Sofern möglich, Batterie vollständig entladen und dann im gekennzeichneten Batterie-Recyclingbehälter entsorgen. Batterien sind Gefahrstoffe und dürfen nicht im Hausmüll landen. Beachten Sie lokale Recyclingvorschriften.
- 2: Bei technischen Defekten, die eine vollständige Entladung verhindern, kontaktieren Sie Fachunternehmen für Batterieentsorgung.
- 3: Tiefentladene Batterien sind nicht mehr startfähig und müssen fachgerecht entsorgt werden.

AUSSCHLUSSKRITERIEN

Die PECRON-Garantie deckt folgende Fälle nicht ab:

Fehlgebrauch, Missbrauch, Modifikationen, Unfallschäden oder Nutzung außerhalb des bestimmungsgemäßen Gebrauchs.

SÍMBOLOS EXPLICATIVOS

⚠ Precauciones importantes ⚙ Indicaciones de uso y manejo

DESCRIPCIÓN DEL PRODUCTO

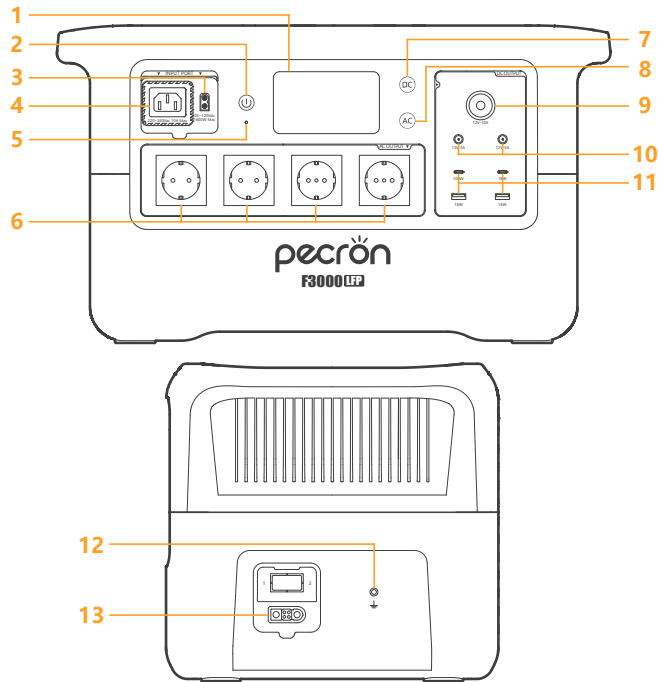

El diseño real puede variar según el país o región. Las especificaciones están sujetas al producto físico.

- | | |
|--------------------------------|-----------------------------------|
| 1 Pantalla LCD | 8 Interruptor AC 220V~240V |
| 2 Interruptor principal | 9 Toma de encendedor DC |
| 3 Puerto de carga DC 25V~120V | 10 Salida DC 5525 |
| 4 Puerto de carga AC 220V~240V | 11 Puertos USB-A/USB-C |
| 5 Luz indicadora LED | 12 Puerto de tierra externa |
| 6 Salida AC 220V~240V | 13 Puerto de expansión de batería |
| 7 Interruptor DC 12V/USB | |

ESPECIFICACIONES TÉCNICAS

INFORMACIÓN GENERAL

Modelo	F3000 LFP
Capacidad	3072Wh(51.2V60Ah)
Peso neto	Aprox. 28.7kg / 63.3lb
Dimensiones	L489*W295*H282 mm / L19.3*W11.6*H11.1 in
Altitud máxima de uso	3000m

ESPECIFICACIONES DE SALIDA

Salida AC*4	Onda sinusoidal pura 220-240Vac potencia máxima 3600W
Salida USB-A*2	(5V,9V,12V,máx. 18W)*2
Salida USB-C*2	(5V,9V,12V,máx. 18W)*1 (5V,9V,12V,20V,máx. 100W)*1
Salida para encendedor*1	DC 12V-10A
Salida DC 5525*2	DC 12V-5A

ESPECIFICACIONES DE ENTRADA

Entrada AC tipo IEC*1	220~240Vac, 50/60Hz, máx. 2200W, máx. 10A
XT60*1	25Vdc~120Vdc, máx. 1600W, máx. 25A

FUNCIÓN DE CASCADA

XT120*1	Admite hasta 2 baterías adicionales en cascada
---------	--

ESPECIFICACIONES DE BATERÍA

Material de celdas	LFP (LiFePO4)
Ciclos de vida	Mantiene >80% capacidad tras 3,500 ciclos

TEMPERATURAS DE OPERACIÓN

Temp. ambiente en descarga	-10°C ~ 45°C / 14°F ~ 113°F
Temp. ambiente en carga	0°C ~ 45°C / 32°F ~ 113°F
Temp. ambiente de almacenamiento	-10°C ~ 45°C / 14°F ~ 113°F

INDICACIONES DE PANTALLA Y OPERACIÓN

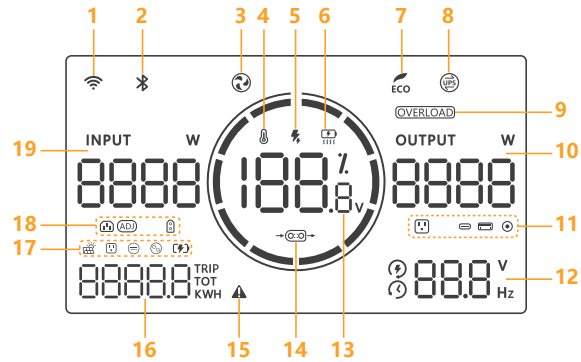

1		Conexión WiFi	13		Porcentaje de carga
2		Conexión Bluetooth	14		Entrada/Cascada/Salida
3		Ventilador	15		Símbolo de alarma
4		Alarma de temperatura	16	TRIP	Energía acumulada (uso único)
5		Carga rápida		TOT	Energía total acumulada
6		Calentamiento de batería activado			Energía consumida
7		Modo ECO	17		Energía solar acumulada
8		UPS (Sistema de alimentación ininterrumpida)			Energía AC acumulada (carga)
9		Alarma por sobrecarga			Energía DC acumulada (salida)
10		Salida AC/DC			Energía AC acumulada (salida)
11		Puerto de salida AC			Energía acumulada de batería
		Puerto de salida USB-C	18		Entrada AC
		Puerto de salida USB-A			Potencia AC ajustada
		Puerto de salida 5521			Entrada DC
12		Tiempo restante de carga	19		Entrada AC/DC
		Autonomía restante			
		Salida AC: voltaje/tiempo/frecuencia			



Parpadeo: Dispositivo reiniciado en modo emparejamiento.



Parpadeo: Protección contra sobrecarga activada. Retire dispositivos para reducir la potencia. La alarma desaparecerá automáticamente al normalizarse la carga.

MANUAL DE USO

- ⏻ **1: Botón principal** Presión breve (0.5s) para encender / presión prolongada para apagar. Cuando está encendido, presión breve apaga la pantalla.
- ⦿ **2: Luz indicadora** Parpadeo blanco: dispositivo en funcionamiento o modo espera. Luz verde fija: carga completa.
- Ⓛ **3: Botón DC** Presión breve cambia entre porcentaje/voltaje. Presión prolongada activa/desactiva DC (con pitido).
- Ⓛ **4: Botón AC** Presión breve cambia entre porcentaje/voltaje. Presión prolongada activa/desactiva AC (con pitido).

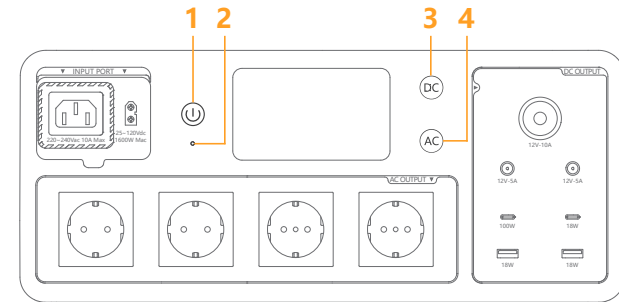

- ⏻ + Ⓛ **Modo ECO:** Presionar botón principal + DC durante 3 segundos (con dispositivo encendido).
- ⏻ **Reinicio para emparejamiento:** Mantener botón principal 5s apagado. Se reiniciará en modo emparejamiento (3 minutos) con iconos Bluetooth/WiFi parpadeando.
- Ⓛ **Menú de configuración:** Mantener botón DC 8s apagado.

MENÚ DE CONFIGURACIÓN

Ⓛ Accesso al menú: Mantener presionado botón DC durante 8 segundos con el equipo apagado.

Ⓛ Presione el botón de apagado para salir, o complete todas las configuraciones hasta el final.

Presión breve en DC: cambiar opción / Presión breve en AC: confirmar y avanzar

1: Potencia de carga AC: 20%~100%
(valor predeterminado 100%)



2: Apagado automático sin salida AC:
OFF/1H/2H/3H/4H
(Predet. OFF)



3: Brillo de botones: OFF/L1/L2/L3
(Predet. L3)



4: Sonido de alarma: ON/OFF
(Predet. ON)

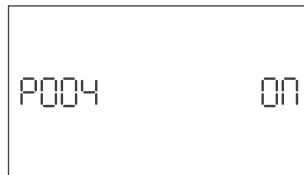

5: Modo anti-toque accidental
(Predet. ON)

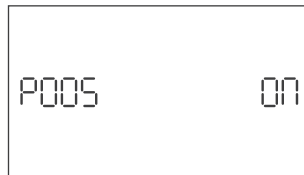

6: Ajuste automático de brillo LCD:
ON/OFF
(Predet. ON)

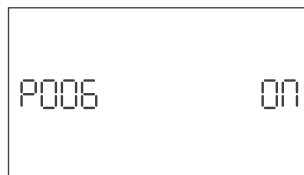

7: Frecuencia de salida AC:
50Hz/60Hz



8: Voltaje de salida AC:
100V/110V/120V (Versión LV)
220V/230V/240V (Versión HV)



9: Configuración de paralelo: ON/OFF
(Predet. OFF)
(No compatible con versión LV)



INTERFAZ DE ESTADÍSTICAS DE USO

En estado encendido/inactivo:
muestra TOT
(energía total acumulada)

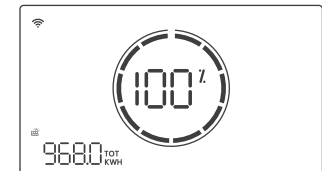

En funcionamiento:
muestra TRIP
(energía consumida desde el encendido)

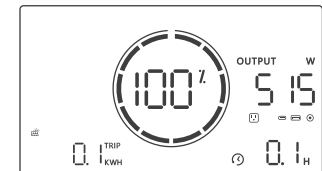

Presión breve en DC (modo inactivo):
alterna entre datos

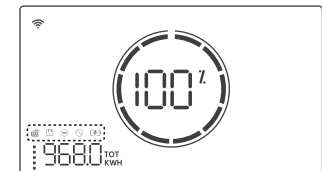

- Energía solar acumulada
- Energía AC acumulada (carga)
- Energía DC acumulada (salida)
- Energía AC acumulada (salida)
- Energía acumulada de batería

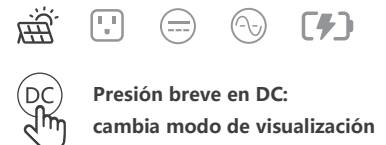

SUMINISTRO DE ENERGÍA MEDIANTE SALIDA AC

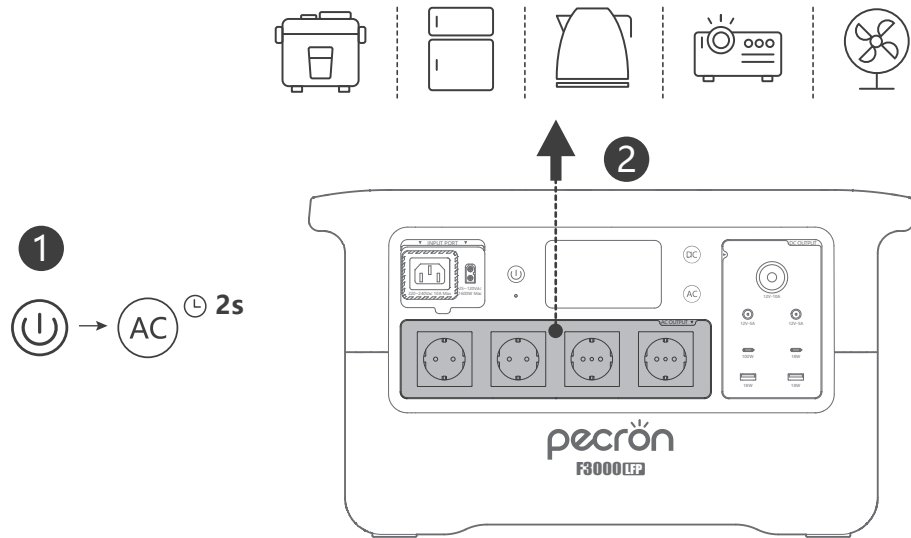

1: Con el equipo encendido, mantenga presionado el botón AC para activar la salida de energía en la zona de conexión correspondiente.

2: Conecte el dispositivo al enchufe de salida AC del producto.

1: Puede presentar ligero olor durante operaciones de alta potencia, es normal y desaparecerá con el uso habitual.



2: Al cargar con entrada AC de frecuencia diferente, el sistema ajustará automáticamente a la frecuencia de entrada.

ALIMENTACIÓN MEDIANTE SALIDA DC

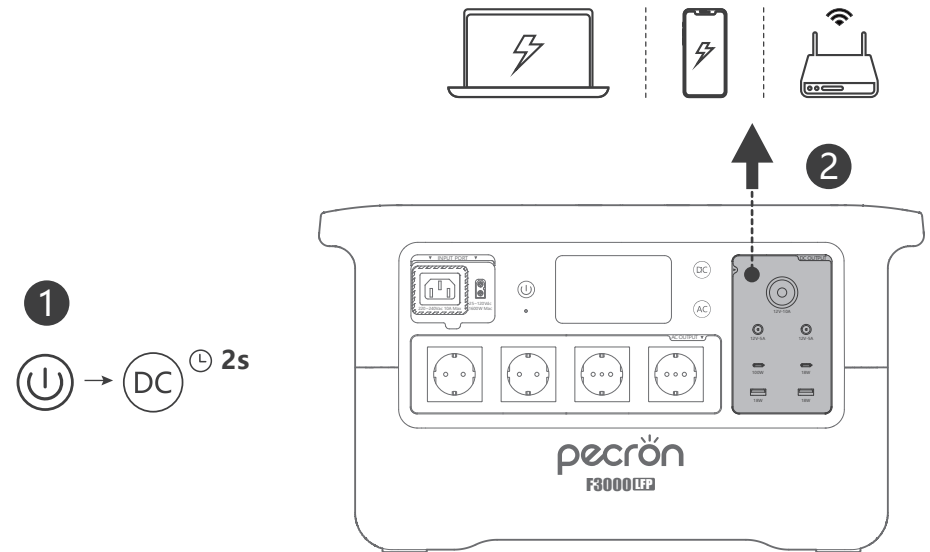

Compatible con cables adaptadores DC (adquiridos por separado) para satisfacer necesidades de carga de diversos dispositivos.

CARGA MEDIANTE AC

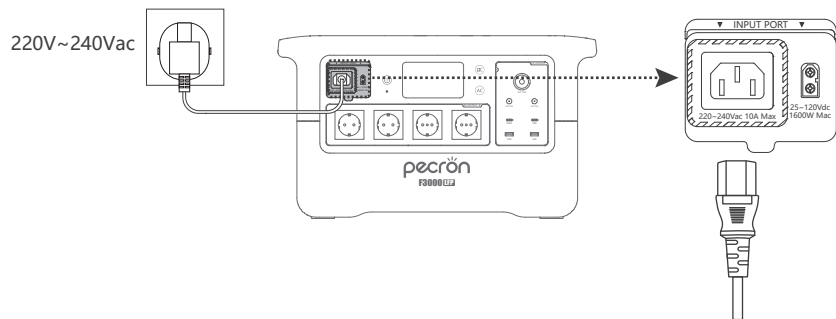

- 1: Desconecte de la red eléctrica al completar la carga.
- 2: Para prolongar la vida útil de las celdas: evite la descarga profunda que pueda dañarlas.
- 3: Durante la carga: si las celdas están muy frías/calientes (icono de alarma parpadeante), la potencia se reducirá automáticamente para seguridad. Es normal.

FUNCIÓN UPS

El F3000 LFP cuenta con función UPS, brindando protección casi instantánea (8-20ms) para cargas como computadoras ante cortes eléctricos. En modo UPS: restaura automáticamente la salida AC. Tras apagón con batería agotada: al restablecerse la red, reactiva automáticamente la salida AC. Límite: 3600W. Se recomienda conectar solo 1 dispositivo para evitar sobrecargas. PECRON no asume responsabilidad por daños o pérdida de datos por uso incorrecto.

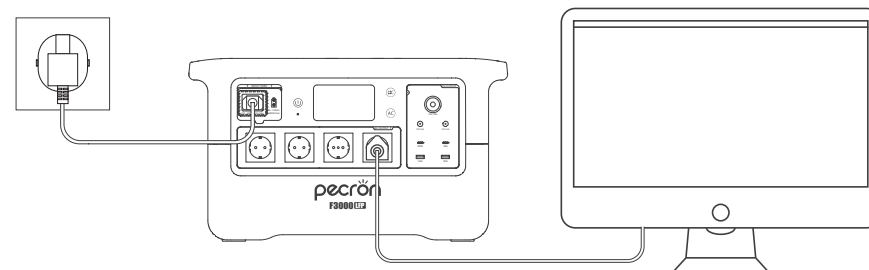

- 1: No apto para aplicaciones críticas (<8ms) como servidores/estaciones de trabajo (riesgo de malfuncionamiento/pérdida de datos).
- 2: Disponibilidad sujeta a regulaciones locales (consultar normativa).

CARGA CON PANEL SOLAR

Pasos de operación:

1: Despliegue el panel solar y fíjelo con el soporte.

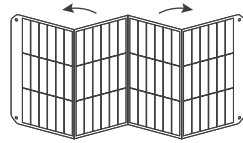

2: Ajuste el ángulo del soporte para alinear directamente el panel con la luz solar.

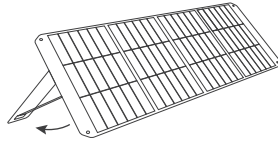

3: Para máxima eficiencia: mantenga incidencia vertical de luz solar sin obstrucciones.

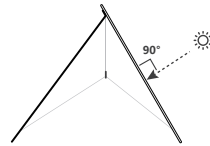

4: Puerto XT60: rango 25-120Vcc, 1600W máx., 25A máx.

En serie: Voltaje total (Voc) < 120V, Vmp > 25V (sumatoria de paneles).

En paralelo: Corriente total (Imp) ≈ I_{max} del puerto.

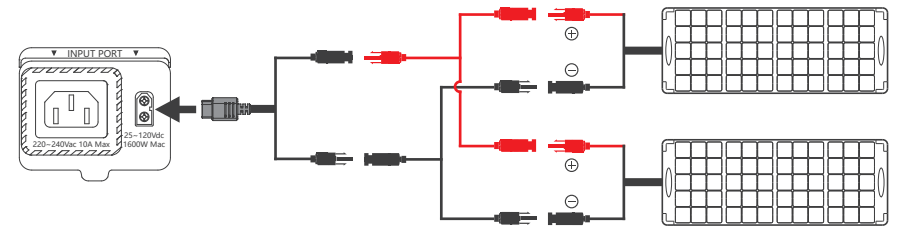
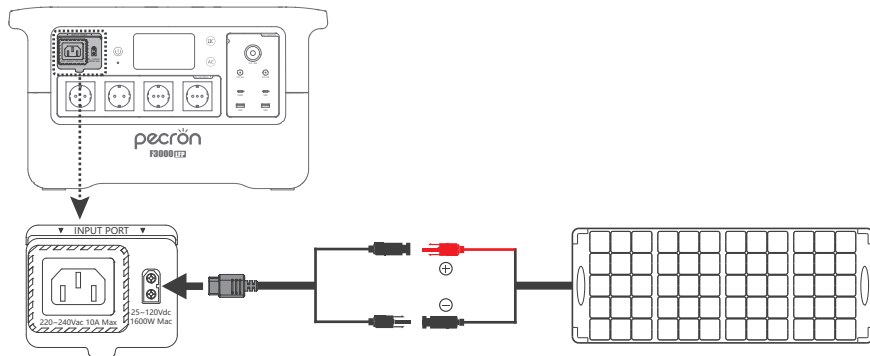

Cable paralelo requiere compra por separado.

- 1: No mezcle tipos de paneles (riesgo de daños).
- 2: Se recomienda panel PECRON para proteger módulos y fuente.
- ⚠ 3: Evite exposición directa al sol en módulos/fuente (sobrecalentamiento).
- 4: Limpie regularmente obstrucciones (reducen eficiencia).
- 5: Limpieza mensual con paño suave ligeramente humedecido.

FUNCIONALIDAD DE LA APP

Conéctese mediante la APP PECRON para: monitoreo, control y configuración personalizada.

Modo de emparejamiento: Con equipo apagado: mantenga el botón de encendido 5s para reiniciar y entrar en modo emparejamiento (3 min). Iconos Bluetooth/WiFi parpadearán.

Descarga e instalación:

Usuarios iPhone: descargue "PECRON" en la App Store.

Usuarios Android: instálelo desde Google Play.



⚠ ¡La conexión de la APP requiere Wi-Fi (2.4G)!

FUNCIÓN DE EXPANSIÓN DE BATERÍA

Conexión mediante puerto XT120 (lado derecho): admite máximo 2 paquetes de batería 48V en cascada.

ADVERTENCIA DE SEGURIDAD: ¡Únicamente use paquetes PECRON! Otros pueden dañar el equipo. Diferencia $\leq 10\%$ entre batería principal y paquetes acelera el emparejamiento.

Puerto XT120: con cable especial PECRON, salida 44-58V DC/40A máx.

LISTA DE PRODUCTOS Y ACCESORIOS

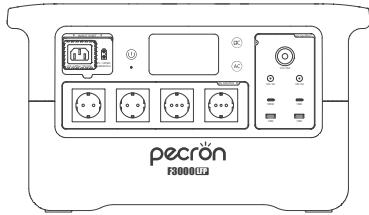

PECRON F3000 LFP *1

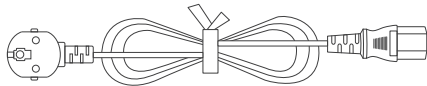

Cable de alimentación AC *1

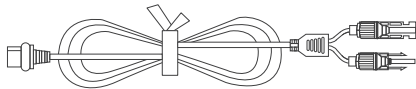

Cable solar XT60 a MC4 *1



Bolsa de accesorios *1

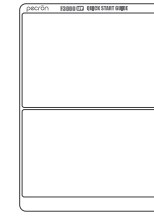

Guía de inicio rápido *1

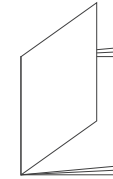

Manual de usuario *1

ACCESORIOS OPCIONALES

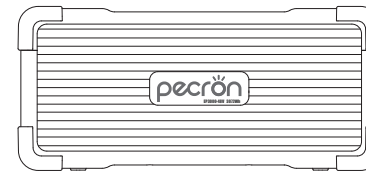

PECRON EP3000-48V

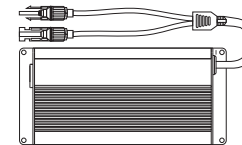

Cargador vehicular inteligente
PECRON 500W

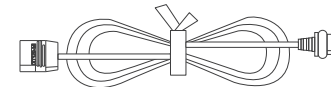

Cable de salida inducida PECRON XT120



Más accesorios disponibles en PECRON oficial

SOLUCIÓN DE FALLOS

Alarma por sobrecarga:
Parpadeo "OVERLOAD" + 2 pitidos

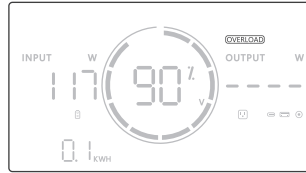

Alarma temperatura:
Símbolo °C parpadeante + 3 pitidos

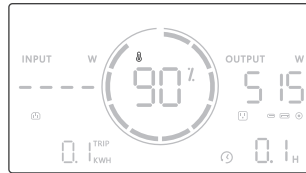

Otras alarmas:
Símbolo "!" parpadeante

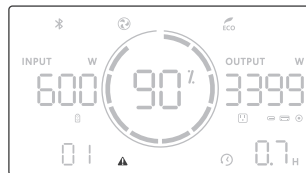

CÓDIGOS DE ALARMA

02	Batería: Voltaje bajo
03	Batería: Sobrecorriente en descarga
04	Batería: Sobrecorriente en carga
05	Batería: Cortocircuito
06	Batería: Cableado desconectado
07	Batería: Carga bloqueada (voltaje crítico)
08	Carga: Temperatura baja
09	Carga: Temperatura alta
10	Descarga: Temperatura baja
11	Descarga: Temperatura alta
12	Error en módulo de carga durante descarga
20	Inversor: Sobrecarga
21	Inversor: Sobrecalentamiento
22	Bus DC: Voltaje fuera de rango
35	Carga DC: Sobrecalentamiento

40 Salida DC: Cortocircuito/Sobrecarga

41 Salida DC: Sobretensión

42 Salida DC: Sobrecorriente

43 Salida DC: Sobrecalentamiento

51 Paquete extra: Voltaje bajo

52 Paquete extra: Sobrecorriente en descarga

53 Paquete extra: Sobrecorriente en carga

54 Paquete extra: Cortocircuito

55 Paquete extra: Cableado desconectado

57 Paquete extra: Carga en temperatura baja

58 Paquete extra: Carga en temperatura alta

59 Paquete extra: Descarga en temperatura baja

60 Paquete extra: Descarga en temperatura alta

PREGUNTAS FRECUENTES

1: ¿Qué celdas usa el F3000 LFP? ¿Vida útil?

Usa celdas LiFePO4 grado automotriz (certificado UL) con >80% capacidad tras 3,500 ciclos.

2: ¿Qué dispositivos puede alimentar?

Dispositivos <3600W AC y/o 12V-10A DC.

3: ¿Tiene función UPS?

Sí, con transición en 8-20ms.

4: ¿Cómo calcular la autonomía?

Fórmula: Autonomía (h) = Capacidad (Wh) × DoD × η ÷ (Potencia carga + Autoconsumo)

Donde:

- DoD: Profundidad de descarga (95%)

- η: Eficiencia inversor (>93%)

- Autoconsumo: 30W

Ejemplo: 3072Wh × 95% × 93% ÷ (40W + 30W) ≈ 39 horas

* Nota: La autonomía real puede variar según condiciones de uso.

5: ¿Carga y descarga simultáneas?

Sí. En modo no-UPS: la potencia de carga debe superar el consumo para evitar apagado.

6: ¿Incluye controlador MPPT?

Sí, con controlador MPPT independiente (puerto XT60: 25-120V/1600W máx.).

7: ¿Otras precauciones?

No es resistente al agua.

Mantenga ventilación adecuada.

Prohibido en minas/gasolineras.

MANTENIMIENTO Y CUIDADO

- 1: Almacene el dispositivo en ambientes entre -10°C (14°F) y 45°C (113°F). Se recomienda mantenerlo entre 0°C (32°F) y 30°C (86°F) para preservar la salud de la batería.
- 2: Guarde el producto en un área segura, seca, fresca y bien ventilada para reducir el riesgo de caídas.
- 3: Mantenga el dispositivo alejado de agua, fuentes de calor, campos magnéticos fuertes, gases corrosivos y materiales inflamables o explosivos.
- 4: Cargue completamente el dispositivo al menos una vez cada 2 meses. Un almacenamiento prolongado sin carga completa causará mediciones inexactas y deterioro de la batería.
- 5: Para almacenamiento prolongado, realice un ciclo de carga/descarga cada 3 meses (cargue al 100%, luego descargue hasta 60% antes de guardar) para mantener la batería saludable.
- 6: No deje el dispositivo sin cargar o usar por más de 6 meses, de lo contrario la garantía se invalidará.
- 7: Limpie el puerto de carga con un paño seco si está sucio. Nunca use alcohol u otros agentes inflamables para limpiar.

DESCARGO DE RESPONSABILIDAD

Antes de usar el producto, lea el manual del usuario para garantizar su uso correcto tras plena comprensión. Tras la lectura, guarde el manual en un lugar seguro para futuras consultas. Un uso incorrecto podría causar lesiones graves a usted u otras personas, así como daños al producto o pérdidas materiales. El uso del producto implica la comprensión, aceptación y conformidad con todos los términos aquí establecidos. El usuario asume toda responsabilidad por sus actos y las consecuencias derivadas de los mismos. La empresa no se hace responsable por pérdidas ocasionadas por el incumplimiento de este documento o del manual de usuario. Bajo el marco legal, la empresa se reserva el derecho de interpretación final de este documento y toda documentación relacionada. Las actualizaciones, modificaciones o discontinuaciones se realizarán sin previo aviso. Consulte el sitio web oficial de PECRON para información actualizada.

USO

- 1: Está estrictamente prohibido acercarse al producto a fuentes de calor (llamas, hornos, etc.) durante su funcionamiento.
- 2: Prohibido el contacto con líquidos. No sumerja, moje ni utilice el producto bajo lluvia o en ambientes húmedos.
- 3: No usar en entornos con alta estática o campos electromagnéticos intensos.
- 4: Prohibido desarmar el producto o perforarlo con objetos afilados.
- 5: No causar cortocircuitos con cables u objetos metálicos.
- 6: No usar para arranque directo de vehículos. Solo para recarga de baterías automotrices.
- 7: No utilice componentes o accesorios no oficiales. Para reemplazos, consulte los canales oficiales de venta PECRON.

- 7: No utilice componentes o accesorios no oficiales. Para reemplazos, consulte los canales oficiales de venta PECRON.
- 8: Respete estrictamente los rangos de temperatura especificados. Temperaturas excesivas pueden causar incendios/explosión; temperaturas muy bajas reducirán drásticamente el rendimiento.
- 9: No coloque objetos pesados sobre el producto.
- 10: No obstruya el ventilador en funcionamiento ni use el producto en espacios sin ventilación o con mucho polvo.
- 11: Evite golpes, caídas o vibraciones fuertes. Si ocurre un impacto severo, apáguelo inmediatamente. Durante transporte, fíjelo adecuadamente.
- 12: Si cae al agua: a) Colóquelo en zona abierta segura b) No reutilizarlo tras secado c) Deséchelo según procedimiento. En caso de incendio, use extintores en este orden: agua/niebla, arena, manta antifuego, polvo químico, CO2.
- 13: Limpie los conectores con paño seco si presentan suciedad.
- 14: Colóquelo con cuidado para evitar vuelcos. Si se cae y sufre daños graves: a) Apague inmediatamente b) Aisle la batería en zona abierta c) Deséchelo según normativas locales.
- 15: Almacene fuera del alcance de niños y mascotas.

DESECHO

- 1: Siempre que sea posible, descargue completamente la batería del producto antes de depositarlo en contenedores designados para reciclaje. Este producto contiene baterías consideradas productos químicos peligrosos, por lo que está estrictamente prohibido desecharlas en basureros comunes. Para más detalles, siga las regulaciones locales sobre reciclaje y eliminación de baterías.
- 2: Si el producto presenta fallas que impiden la descarga completa de la batería, no la deseche directamente en contenedores de reciclaje. Contacte a una empresa especializada en reciclaje de baterías para su correcto tratamiento.
- 3: Si la batería ha sido sobredescargada y no puede reactivarse, debe proceder con su desecho según las instrucciones anteriores.

EXCLUSIONES DE GARANTÍA

La garantía de PECRON no cubre los siguientes casos:

Mal uso, abuso, modificaciones, daños accidentales o cualquier uso fuera del propósito de consumo normal.

SYMBOLES ET LÉGENDES

⚠ Avertissements importants ☀ Instructions d'utilisation

PRÉSENTATION DU PRODUIT

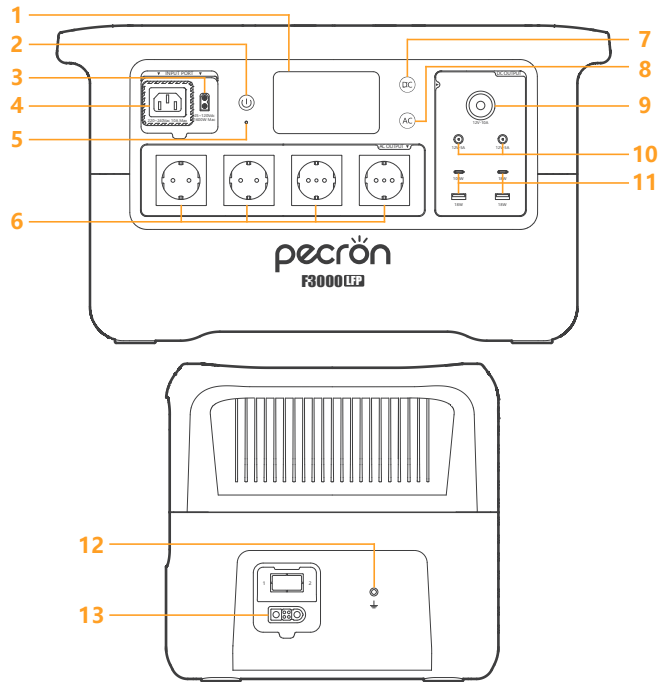

L' apparence et la structure du produit peuvent varier selon les pays/régions. Seule la version physique fait foi.

- | | |
|--------------------------------|-------------------------------|
| 1 Écran LCD | 8 Interrupteur AC 220V~240V |
| 2 Interrupteur principal | 9 Prise allume-cigare DC |
| 3 Port de charge DC 25V~120V | 10 Sortie DC 5525 |
| 4 Port de charge AC 220V~240V | 11 Ports USB-A / USB-C |
| 5 LED indicative (respiration) | 12 Port de mise à la terre |
| 6 Sortie AC 220V~240V | 13 Port d' extension batterie |
| 7 Interrupteur DC 12V / USB | |

CARACTÉRISTIQUES TECHNIQUES

INFORMATIONS GÉNÉRALES

Modèle	F3000 LFP
Capacité	3072Wh(51.2V60Ah)
Poids net	Environ 28,7 kg / Environ 63,3 lb
Dimensions	L489*W295*H282 mm / L19.3*W11.6*H11.1 in
Altitude maximale d'utilisation	3000m

SORTIES

Sortie AC*4	Onde sinusoïdale pure 220~240Vac puissance maximale 3600W
Sortie USB-A*2	(5V,9V,12V,max 18W)*2
Sortie USB-C*2	(5V,9V,12V,max 18W)*1 (5V,9V,12V,20V,max 100W)*1
Sortie allume-cigare*1	DC 12V-10A
Sortie DC 5525*2	DC 12V-5A

ENTRÉES

Entrée AC*1	220~240Vac, 50/60Hz, Max 2200W, Max 10A
XT60*1	25Vdc~120Vdc, Max 1600W, Max 25A

FONCTION CASCADE

XT120*1	Peut être connecté en cascade avec 2 batteries supplémentaires max
---------	---

CARACTÉRISTIQUES DE LA BATTERIE

Matériau des cellules	LFP (Lithium Fer Phosphate)
Durée de vie	Conserve plus de 80% de capacité après 3500 cycles

TEMPÉRATURES DE FONCTIONNEMENT

Température ambiante en décharge	-10°C ~ 45°C / 14°F ~ 113°F
Température ambiante en charge	0°C ~ 45°C / 32°F ~ 113°F
Température ambiante de stockage	-10°C ~ 45°C / 14°F ~ 113°F

AFFICHAGE ET INSTRUCTIONS D'UTILISATION

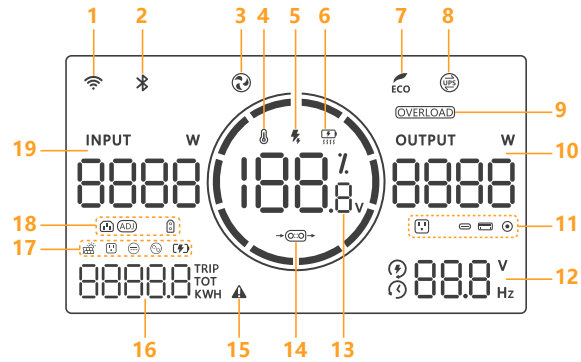

1		Connexion WiFi	13		Pourcentage de charge
2		Connexion Bluetooth	14		Entrée/Connexion cascade/Sortie
3		Ventilateur	15		Symbole d'alarme
4		Alarme de température	16	TRIP	Énergie cumulée (session)
5		Charge rapide		TOT	Énergie totale cumulée
6		Chauffage de batterie activé			Énergie utilisée
7		Mode ECO	17		Énergie solaire cumulée
8		UPS (on garde l'acronyme anglais)			Énergie AC cumulée (charge)
9		Alarme de surcharge			Énergie DC cumulée (sortie)
10		Sortie AC/DC			Énergie AC cumulée (sortie)
11		Prise de sortie AC			Énergie batterie cumulée (sortie)
		Prise de sortie USB-C	18		Entrée AC
		Prise de sortie USB-A			Puissance AC ajustée
		Prise de sortie 5521			Entrée DC
12		Temps de charge restant	19		Entrée AC/DC
		Temps d'utilisation restant			
		Tension/fréquence/temps AC			



Clignotement : Produit réinitialisé en mode appairage.



Clignotement : Protection contre la surcharge activée. Débranchez certains appareils pour réduire la puissance totale. L'alarme s'éteindra automatiquement lorsque la puissance reviendra à la normale.

MODE D'EMPLOI

- Ⓛ 1: **Bouton d'alimentation principal**
Appuyez brièvement (0,5 s) pour allumer/maintenez enfoncé pour éteindre. Une fois allumé, appuyez brièvement pour éteindre l'écran.
- Ⓛ 2: **LED indicative** Clignotement blanc : appareil en marche ou en veille.
Vert fixe : charge complète.
- Ⓛ DC 3: **Bouton DC** Sous tension : appuyez brièvement pour afficher tension/pourcentage ; maintenez pour activer/désactiver DC (un bip confirme).
- Ⓛ AC 4: **Bouton AC** Sous tension : appuyez brièvement pour afficher tension/pourcentage ; maintenez pour activer/désactiver AC (un bip confirme).

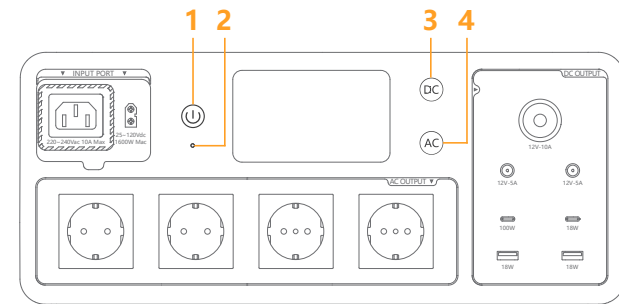

- Ⓛ + Ⓛ DC Mode ECO: Sous tension : maintenez bouton power + DC 3 secondes pour activer.
- Ⓛ Réinitialisation et mode appairage: Éteint : maintenez le bouton 5 s pour réinitialiser et entrer en mode appairage (3 min). Les icônes Bluetooth/WiFi clignotent.
- Ⓛ DC Accès aux paramètres utilisateur: Éteint : maintenez le bouton DC 8 secondes pour accéder aux réglages.

INTERFACE DES PARAMÈTRES UTILISATEUR

Ⓚ Accès au menu des paramètres : Appareil éteint : maintenir le bouton DC enfoncé 8 secondes pour accéder aux paramètres.

Ⓛ Appuyer sur le bouton marche/arrêt pour quitter, ou terminer en arrivant à la dernière page.

Appui court sur DC pour changer de paramètre, appui court sur AC pour valider.

1: Puissance de charge AC:

Plage de réglage : 20%~100% (100% par défaut)



2: Arrêt automatique sans sortie AC:

OFF/1H/2H/3H/4H

(Désactivé par défaut)



3: Luminosité des boutons: OFF/L1/L2/L3

(Niveau L3 par défaut)



4: Signal sonore: ON/OFF

(Activé par défaut)

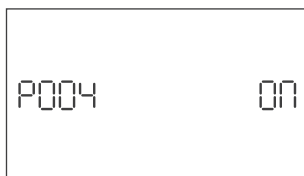

5: Mode anti-fausse manipulation

(Activé par défaut)



6: Réduction automatique luminosité écran:

ON/OFF

(Activé par défaut)



7: Fréquence de sortie AC: 50Hz/60Hz

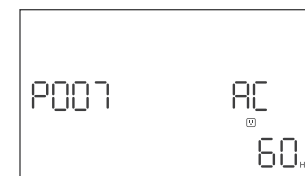

8: Tension de sortie AC:

100V/110V/120V (Version LV)

220V/230V/240V (Version HV)

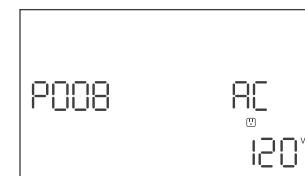

9: Paramètres mode parallèle: ON/OFF

(Désactivé par défaut)

(Non supporté par version LV)

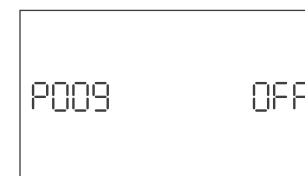

INTERFACE DES STATISTIQUES

À l'allumage sans charge : affichage TOT
(énergie totale cumulée).

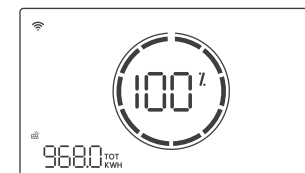

En fonctionnement : affichage TRIP
(énergie consommée depuis l'allumage).

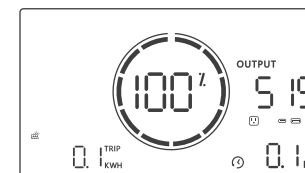

Allumé sans charge :

appui court sur DC pour changer l'affichage.

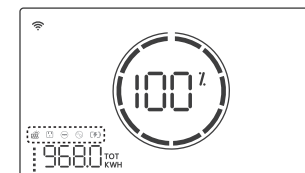

- Énergie solaire cumulée
- Énergie AC cumulée (charge)
- Énergie DC cumulée (sortie)
- Énergie AC cumulée (sortie)
- Énergie batterie cumulée (sortie)



ALIMENTATION DES APPAREILS VIA SORTIE AC

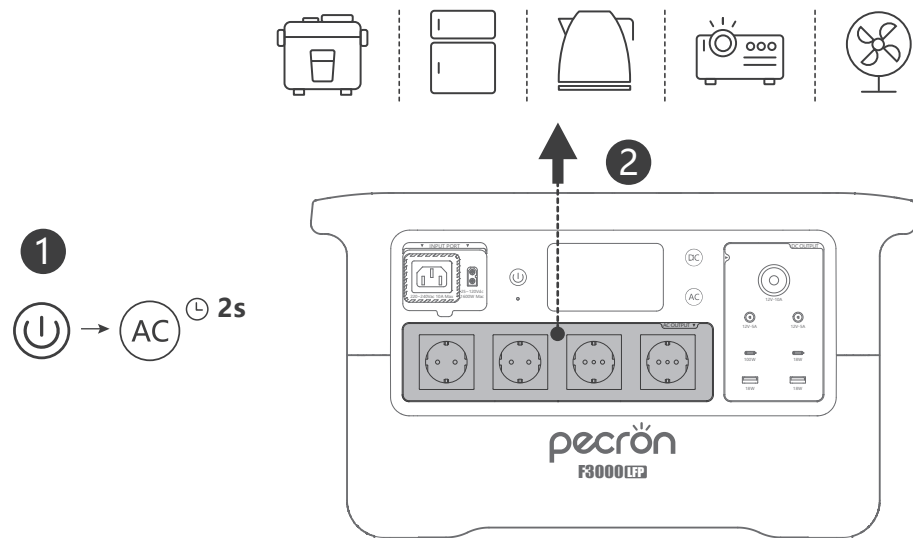

- 1: Lorsque l'appareil est allumé, maintenir le bouton AC enfoncé pour activer l'alimentation des ports correspondants.
- 2: Connecter l'appareil à la prise de sortie AC.

- 💡 1: Une légère odeur peut apparaître lors des fortes puissances, phénomène normal qui disparaît avec l'usage.
- 2: L'alimentation ajuste automatiquement sa fréquence de sortie à celle de l'entrée AC.

ALIMENTATION DES APPAREILS VIA SORTIE DC

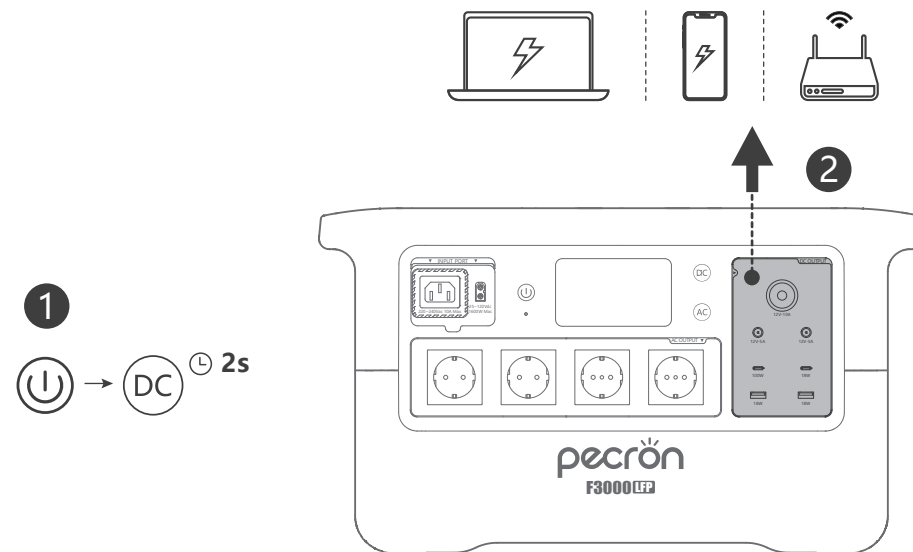

L'alimentation peut être utilisée avec des câbles adaptateurs DC (à acheter séparément) pour répondre aux besoins de charge de différents appareils.

CHARGE VIA SECTEUR AC

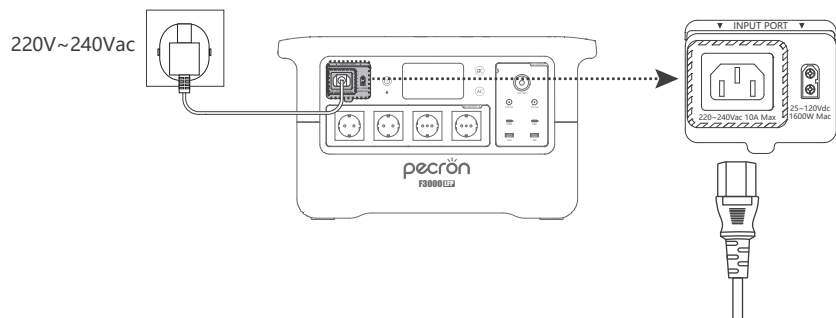

- 1: Débrancher l'alimentation secteur après charge complète.
- 2: Pour prolonger la durée de vie des cellules, éviter les décharges profondes pouvant les endommager.
- 3: Si la température des cellules est trop haute ou basse, l'icône d'alerte clignote et la puissance de charge diminue automatiquement pour sécurité - phénomène normal.

FONCTION UPS (ONDULEUR)

Le F3000 LFP dispose d'une fonction UPS. Il protège les appareils connectés (ex: ordinateur) contre les coupures de courant en fournissant une alimentation de secours quasi instantanée (en 8 à 20 ms). En mode UPS, l'alimentation rétablit automatiquement la sortie AC. Après une panne totale et décharge complète, la sortie AC se réactive automatiquement au retour du secteur. Cette fonction UPS ne supporte que des charges $\leq 3600W$. Nous recommandons de ne connecter qu'un seul appareil pour éviter toute surcharge. PECRON décline toute responsabilité en cas de dommages matériels ou pertes de données dus à un usage non conforme.

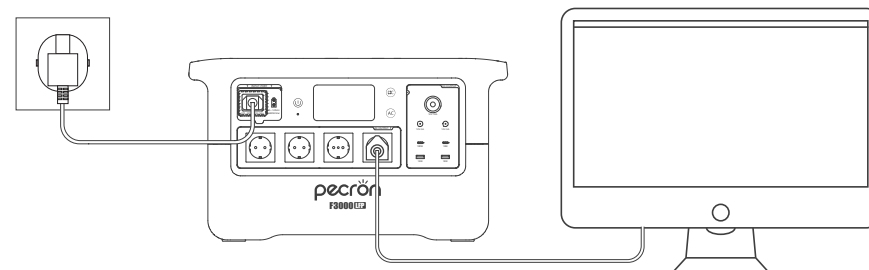

- 1: Incompatible avec les applications critiques nécessitant $< 8ms$ de basculement (serveurs, stations de travail), sous peine de dysfonctionnements ou pertes de données.
- 2: Non disponible dans certaines régions - se référer à la réglementation locale.

CHARGE VIA PANNEAU SOLAIRE

Procédure :

1: Déployer le panneau solaire et le fixer avec le support.

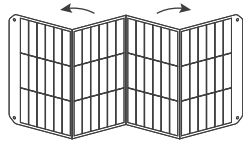

2: Ajuster l'angle du panneau via le support pour un ensoleillement optimal.

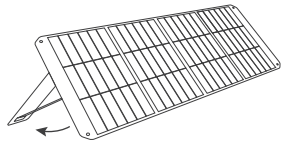

3: Pour maximiser l'efficacité, maintenir une exposition perpendiculaire au soleil sans obstruction.

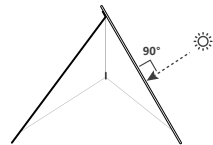

4: Le port XT60 accepte 25-120Vdc (max 1600W/25A).

En série : tension totale = Σ tensions panneaux ($V_{oc} < 120V$, $V_{mp} > 25V$).

En parallèle : courant total \approx courant max (I_{max}) de l'entrée.

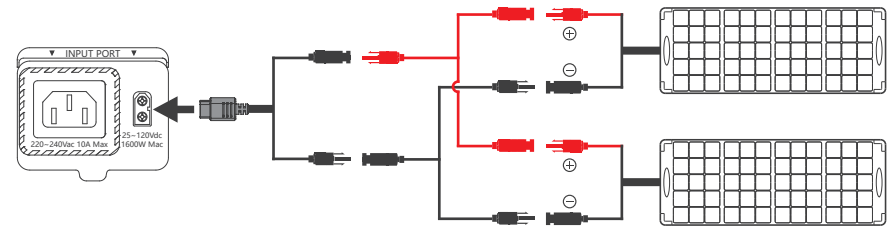
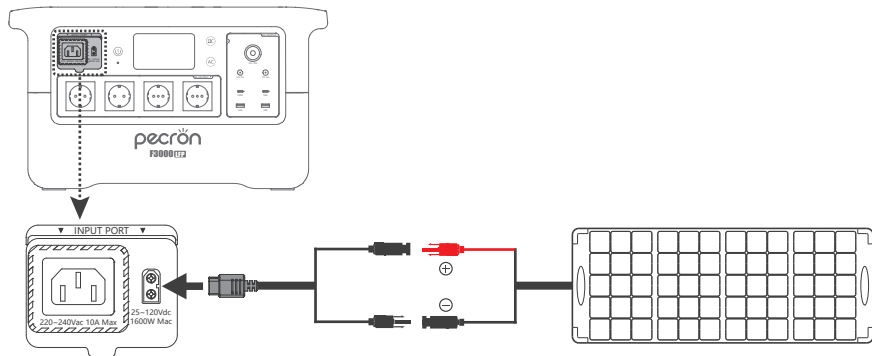

Câble parallèle à acheter séparément.

1: Ne pas mélanger différents types de panneaux (risque de dommages).

2: Recommandé : panneaux PECRON pour préserver les circuits.

⚠ 3: Éviter l'exposition directe des modules au soleil (suréchauffement).

4: Nettoyer régulièrement la surface (les ombres réduisent l'efficacité).

5: Nettoyer avec un chiffon doux légèrement humide.

FONCTIONNALITÉ DE L'APPLICATION

Vous pouvez connecter ce produit via l'application PECRON pour visualiser les informations, contrôler l'appareil et personnaliser les paramètres.

Lorsque l'appareil est éteint, maintenez le bouton d'alimentation enfoncé pendant 5 secondes pour le réinitialiser et activer le mode d'appairage (3 minutes). Les icônes Bluetooth/WiFi clignotent alors.

Les utilisateurs iPhone peuvent télécharger l'application PECRON sur l'Apple Store.

Les utilisateurs Android peuvent trouver PECRON sur Google Play pour le téléchargement et l'utilisation.



⚠ La connexion à l'application nécessite un Wi-Fi (2.4 GHz) !

FONCTION DU PORT D'EXTENSION DE BATTERIE

Vous pouvez utiliser la prise XT120 sur le côté droit de l'appareil pour connecter jusqu'à deux blocs d'alimentation supplémentaires 48V via un câble de cascade.

Il est strictement interdit d'utiliser des blocs d'alimentation non-PECRON, sous peine d'endommager l'appareil !

Remarque sur la cascade : une différence de charge $\leq 10\%$ entre l'appareil principal et les blocs supplémentaires accélère la mise en cascade.

Le port d'extension (XT120) peut fournir une tension de batterie (44V~58V) avec un courant max de 40A via un câble spécial PECRON.

CONTENU DE L'EMBALLAGE

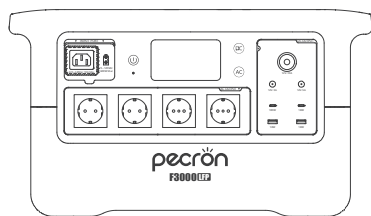

PECRON F3000 LFP *1

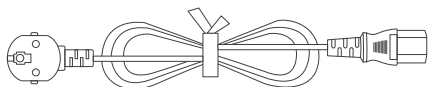

Câble d'alimentation AC *1

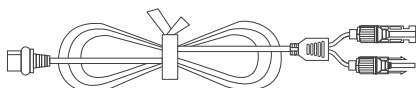

Câble de charge solaire XT60 vers MC4 *1



Sachet d'accessoires *1

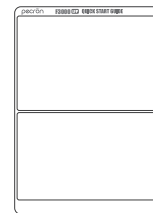

Guide de prise en main rapide *1

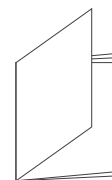

Guide d'utilisation *1

ACCESSOIRES OPTIONNELS



PECRON EP3000-48V

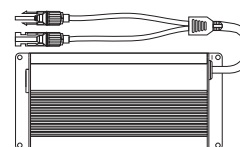

Chargeur intelligent
vehicule PECRON 500W

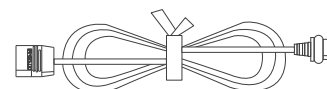

Câble de sortie spécial XT120 PECRON



Plus d'accessoires disponibles
sur le site officiel PECRON

DIAGNOSTIC DES PROBLÈMES

Alarme de surcharge :
"OVERLOAD" clignote + 2 bips

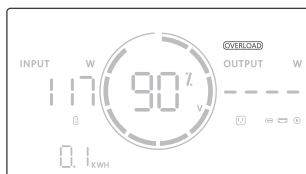

Alarme température batterie :
icône °C clignote + 3 bips

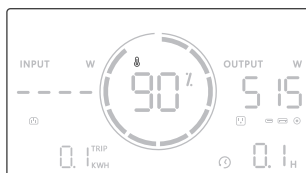

Autres alarmes :
point d'exclamation clignotant

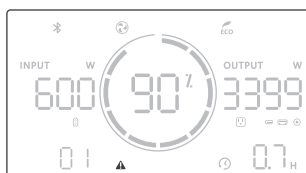

ALERTES SYSTÈME

- 02 Tension batterie trop basse
- 03 Surintensité décharge batterie
- 04 Surintensité charge batterie
- 05 Court-circuit batterie
- 06 Câble batterie déconnecté
- 07 Charge bloquée (tension trop basse)
- 08 Température charge trop basse
- 09 Température charge trop élevée
- 10 Température décharge trop basse
- 11 Température décharge trop élevée
- 12 Anomalie circuit charge pendant décharge
- 20 Surcharge onduleur
- 21 Surchauffe onduleur
- 22 Tension bus anormale
- 35 Surchauffe charge DC

- 40 Court-circuit/surcharge sortie DC
- 41 Tension sortie DC trop élevée
- 42 Intensité sortie DC trop élevée
- 43 Température sortie DC trop élevée
- 51 Tension bloc additionnel trop basse
- 52 Surintensité décharge bloc additionnel
- 53 Surintensité charge bloc additionnel
- 54 Court-circuit bloc additionnel
- 55 Câble bloc additionnel déconnecté
- 57 Température charge bloc additionnel trop basse
- 58 Température charge bloc additionnel trop élevée
- 59 Température décharge bloc additionnel trop basse
- 60 Température décharge bloc additionnel trop élevée

FAQ (FOIRE AUX QUESTIONS)

1: Quelle technologie de cellules utilise le F3000 LFP ? Quelle est sa durée de vie ?

Le F3000 LFP utilise des cellules LiFePO4 (Lithium Fer Phosphate) de qualité automobile, certifiées UL, conservant >80% de capacité après 3500 cycles complets.

2: Quels appareils peuvent être alimentés par le F3000 LFP ?

Tous appareils $\leq 3600W$ AC et $\leq 12V/10A$ DC.

3: Le F3000 LFP dispose-t-il d'une fonction UPS ?

Oui, avec basculement en 8-20 ms maximum.

4: Comment calculer l'autonomie du F3000 LFP ?

Formule : $\text{Autonomie (h)} = \text{Capacité (Wh)} \times \text{DoD} \times \eta \div (\text{Puissance charge} + \text{Autoconsommation})$

Note : DoD = Profondeur de décharge ; η = Rendement onduleur (>93%) ;

Autoconsommation $\approx 30W$.

Exemple : $3072Wh \times 95\% \times 93\% \div (40W+30W) \approx 39h$.

Ces estimations peuvent varier selon les conditions réelles (froid, surcharge, etc.).

5: Charge et décharge simultanées possibles ?

Oui, mais en mode non-UPS, la puissance de charge doit excéder la consommation pour éviter l'arrêt.

6: Contrôleur MPPT intégré ?

Oui, contrôleur MPPT dédié via port XT60 (25-120V, max 1600W).

7: Autres précautions ?

Étanche : Non - éviter tout contact avec l'eau.

Maintenir une ventilation adéquate des grilles d'aération.

Interdit en zones dangereuses (mines, stations-service...).

MAINTENANCE ET ENTRETIEN

- 1: Stocker l'appareil entre -10°C et 45°C (idéalement 0°C à 30°C) pour préserver la batterie.
- 2: Conserver dans un endroit sec, frais, bien ventilé et sécurisé pour éviter les chutes.
- 3: Éloigner de l'eau, sources de chaleur, champs magnétiques intenses, gaz corrosifs et matières inflammables/explosives.
- 4: Effectuer une charge complète au moins tous les 2 mois pour éviter les erreurs d'affichage et déséquilibres des cellules.
- 5: Pour stockage prolongé : cycle charge/décharge complet tous les 3 mois (recharger puis décharger à 60%).
- 6: Ne pas laisser sans charge/utilisation plus de 6 mois (annulation de garantie).
- 7: Nettoyer les connecteurs avec un chiffon sec. Interdiction d'utiliser alcool ou produits inflammables.

CLAUSE DE NON-RESPONSABILITÉ

Avant utilisation, veuillez lire le manuel utilisateur pour garantir une utilisation correcte après une compréhension complète. Après lecture, conservez soigneusement le manuel pour référence ultérieure. Une mauvaise utilisation du produit peut entraîner des blessures graves, des dommages matériels ou des pertes financières. L'utilisation du produit vaut acceptation de l'intégralité des clauses et conditions du présent document. L'utilisateur s'engage à assumer l'entière responsabilité de ses actes et de leurs conséquences. Notre société décline toute responsabilité pour les dommages résultant d'une non-conformité aux instructions.

Conformément à la loi, notre société se réserve le droit d'interprétation finale de ce document et de toute documentation associée. Les mises à jour, modifications ou résiliations se feront sans préavis - consultez le site officiel PECRON pour les dernières informations.

MISES EN GARDE

- 1: Il est strictement interdit d'approcher le produit en fonctionnement d'une source de chaleur (flamme, radiateur, etc.).
- 2: Tout contact avec des liquides est interdit. Ne pas immerger ou mouiller le produit. À proscrire en milieu humide ou sous la pluie.
- 3: Usage prohibé dans des environnements à forte charge électrostatique ou champ magnétique intense.
- 4: Toute tentative de démontage ou perforation avec des objets pointus est formellement interdite.
- 5: Ne provoquez pas de court-circuit avec des fils métalliques ou autres objets conducteurs.
- 6: Ce produit ne doit pas servir à démarrer un véhicule, mais uniquement à recharger la batterie.
- 7: N'utilisez que des pièces et accessoires officiels. Pour tout remplacement, consultez les canaux de vente agréés PECRON.

- 8: Respectez scrupuleusement les plages de température d'utilisation spécifiées. Une température excessive peut provoquer un incendie/explosion ; un froid intense altérera gravement les performances.
- 9: Ne placez aucun objet lourd sur le produit.
- 10: Ne bloquez pas le ventilateur en marche et évitez les espaces non ventilés ou poussiéreux.
- 11: Évitez chocs, chutes et vibrations violentes. En cas d'impact majeur, éteignez immédiatement l'appareil. Pour le transport, maintenez-le fermement.
- 12: Si le produit tombe dans l'eau, placez-le dans une zone dégagée et attendez son séchage complet (ne plus l'utiliser ensuite, suivez les instructions de recyclage). En cas d'incendie, utilisez dans l'ordre : eau/brouillard d'eau, sable, couverture anti-feu, extincteur à poudre ou CO2.
- 13: Nettoyez les connecteurs souillés avec un chiffon sec.
- 14: Placez le produit avec précaution pour éviter les basculements. En cas de chute avec dommages importants, isolez la batterie dans un espace ouvert et recyclez conformément à la réglementation locale.
- 15: Rangez hors de portée des enfants et animaux domestiques.

MISE AU REBUT

- 1: Si possible, déchargez complètement la batterie avant de la placer dans un conteneur de recyclage dédié. Les batteries contenant des substances dangereuses sont interdites dans les ordures ménagères. Respectez la réglementation locale sur le recyclage des batteries.
- 2: Si la batterie ne peut être déchargée en raison d'un dysfonctionnement, ne la jetez pas dans un conteneur de recyclage. Contactez une entreprise spécialisée dans le traitement des batteries.
- 3: Une batterie totalement déchargée ne peut plus être utilisée et doit être mise au rebut selon les procédures appropriées.

CAS D'EXCLUSION DE GARANTIE

La garantie PECRON ne couvre pas les cas suivants :

mauvaise utilisation, abus, modification, dommages accidentels ou toute utilisation non conforme à sa destination normale.

SIMBOLOGIA

⚠ Avvertenze importanti 💡 Istruzioni operative e suggerimenti d'uso

PRESENTAZIONE DEL PRODOTTO

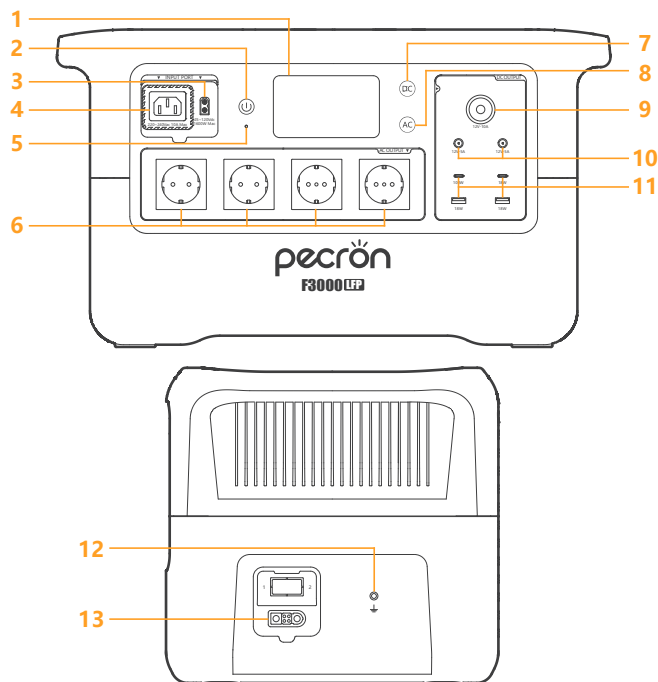

L'aspetto e la struttura effettivi del prodotto possono variare a seconda del paese o della regione.
Fa fede il prodotto fisico.

- | | |
|----------------------------------|-----------------------------------|
| 1 Display LCD | 8 Interruttore AC 220V~240V |
| 2 Interruttore generale | 9 Presa accendisigari DC |
| 3 Porta di ricarica DC 25V~120V | 10 Uscita DC 5525 |
| 4 Porta di ricarica AC 220V~240V | 11 Porta USB-A / USB-C |
| 5 Luce di respirazione | 12 Porta di messa a terra esterna |
| 6 Uscita AC 220V~240V | 13 Porta di espansione batteria |
| 7 Interruttore DC 12V / USB | |

SPECIFICHE TECNICHE

INFORMAZIONI GENERALI

Modello	F3000 LFP
Capacità	3072Wh(51.2V60Ah)
Peso netto	Circa 28,7 kg / Circa 63,3 lb
Dimensioni	L489*W295*H282 mm / L19.3*W11.6*H11.1 in
Altitudine massima di utilizzo	3000m

SPECIFICHE DI USCITA

Uscita AC*4	Onda sinusoidale pura 220~240Vac potenza nominale massima 3600W
Uscita USB-A*2	(5V,9V,12V,massimo 18W)*2
Uscita USB-C*2	(5V,9V,12V,massimo 18W)*1 (5V,9V,12V,20V,massimo 100W)*1
Uscita accendisigari*1	DC 12V-10A
Uscita DC 5525*2	DC 12V-5A

SPECIFICHE DI INGRESSO

Preso AC a 3 poli*1	220~240Vac, 50/60Hz, Massimo 2200W, Massimo 10A
XT60*1	25Vdc~120Vdc, Massimo 1600W, Massimo 25A

FUNZIONE CASCATA

XT120*1	Fino a 2 power pack collegabili in cascata
---------	--

SPECIFICHE DELLA BATTERIA

Materiale della cella	LFP (litio ferro fosfato)
Ciclo di vita	Mantiene oltre l'80% della capacità dopo 3500 cicli

TEMPERATURE OPERATIVE

Temperatura ambientale (funzionamento)	-10°C ~ 45°C / 14°F ~ 113°F
Temperatura ambientale (ricarica)	0°C ~ 45°C / 32°F ~ 113°F
Temperatura ambientale (conservazione)	-10°C ~ 45°C / 14°F ~ 113°F

INDICAZIONI DEL DISPLAY E OPERAZIONI

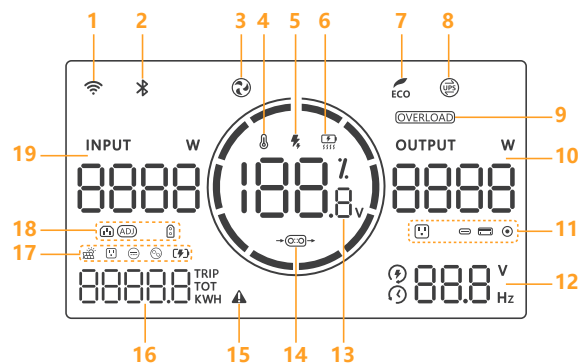

1		Connessione WiFi	13		Percentuale carica batteria
2		Connessione Bluetooth	14		Ingresso/collegamento cascata /uscita
3		Ventilatore	15		Simbolo allarme
4		Allarme temperatura	16	TRIP	Energia accumulata singolo utilizzo
5		Ricarica rapida		TOT	Energia totale accumulata
6		Riscaldamento batteria attivato			Energia consumata
7		Modalità ECO	17		Mostra energia totale ricarica solare
8		UPS (gruppo di continuità)			Mostra energia totale ricarica AC
9	OVERLOAD	Allarme sovraccarico			Mostra energia totale uscita DC
10		Uscita AC/DC			Mostra energia totale uscita AC
11		Presa uscita AC			Mostra energia totale uscita batteria
		Presa uscita USB-C	18		Ingresso AC
		Presa uscita USB-A			Potenza AC regolata
		Presa uscita 5521			Ingresso DC
12		Tempo rimanente ricarica	19		Ingresso AC/DC
		Tempo rimanente utilizzo			
		Tensione/tempo/frequenza uscita AC			



Lampeggiante: prodotto ripristinato e in modalità abbinamento.



Lampeggiante: protezione sovraccarico attivata. Rimuovere alcuni dispositivi collegati per ridurre la potenza totale. L'allarme si disattiverà automaticamente quando la potenza tornerà a livelli normali.

ISTRUZIONI PER L'USO

- Ⓛ1: **Pulsante d'accensione principale** Premere brevemente (0,5 secondi) per accendere / Premere a lungo per spegnere. A dispositivo acceso, premere brevemente per disattivare lo schermo.
- Ⓛ2: **Luce di stato** Lampeggio bianco: dispositivo in funzione o standby.
Luce verde fissa: carica della batteria completata.
- ⓁDC3: **Pulsante DC** A dispositivo acceso: premere brevemente per alternare la visualizzazione percentuale/tensione; premere a lungo per attivare/disattivare DC (con segnale acustico).
- ⓁAC4: **Pulsante AC** A dispositivo acceso: premere brevemente per alternare la visualizzazione percentuale/tensione; premere a lungo per attivare/disattivare AC (con segnale acustico).

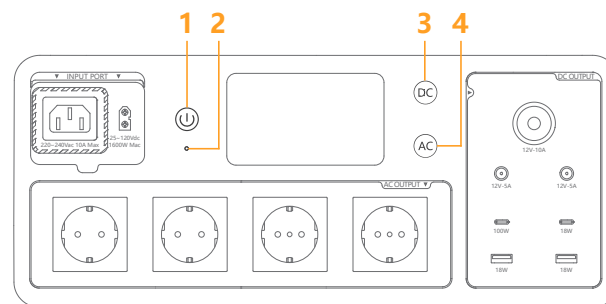

- Ⓛ1 + ⓁDC Modalità ECO: A dispositivo acceso, tenere premuti i pulsanti d'accensione + DC per 3 secondi per attivare la modalità ECO.
- Ⓛ1 Ripristino e modalità pairing: A dispositivo spento, tenere premuto il pulsante d'accensione per 5 secondi per riavviare e avviare la modalità pairing (3 minuti), con icone Bluetooth/WiFi lampeggianti.
- ⓁDC Accesso menu impostazioni: A dispositivo spento, tenere premuto il pulsante DC per 8 secondi per accedere al menu delle impostazioni utente.

MENU IMPOSTAZIONI UTENTE

Ⓚ Accesso menu impostazioni: Tenere premuto il tasto DC per 8 secondi a dispositivo spento.

Ⓛ Premere il tasto d'accensione per uscire, oppure completare tutte le pagine impostazioni.

Breve pressione DC: cambia impostazione - Breve pressione AC: conferma e prosegue.

1: Potenza ricarica AC: 20%~100%
(default 100%)



2: Spegnimento automatico senza uscita AC:
OFF/1H/2H/3H/4H
(default OFF)

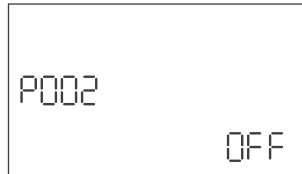

3: Luminosità pulsanti: OFF/L1/L2/L3
(default L3)



4: Segnale acustico: ON/OFF
(default ON)

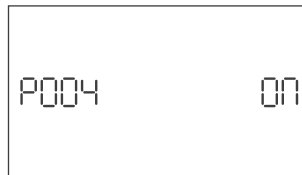

5: Modalità anti-erronea:
(default ON)

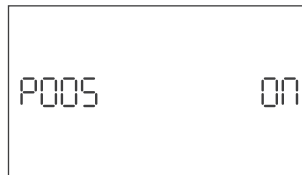

6: Riduzione automatica luminosità LCD:
ON/OFF
(default ON)

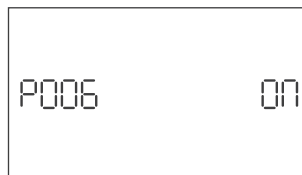

7: Frequenza uscita AC: 50Hz/60Hz



8: Tensione uscita AC:
100V/110V/120V (Versione LV)
220V/230V/240V (Versione HV)



9: Modalità parallelo: ON/OFF
(default OFF)
(Non supportato in versione LV)



SCHEMATA STATISTICHE USO

A dispositivo acceso ma inattivo:
mostra TOT
(energia totale accumulata).

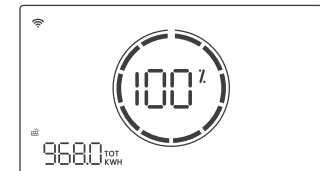

In funzione: mostra TRIP
(energia consumata dalla riaccensione).

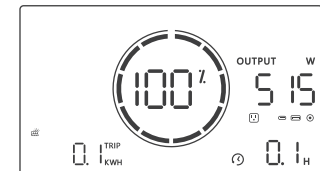

A dispositivo acceso/inattivo:
breve pressione DC alterna i dati.

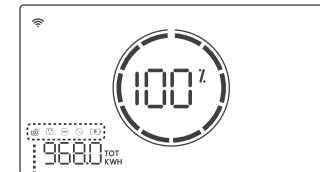

- Mostra energia totale ricarica solare
- Mostra energia totale ricarica AC
- Mostra energia totale uscita DC
- Mostra energia totale uscita AC
- Mostra energia totale uscita batteria

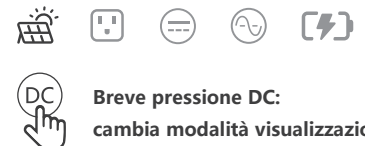

Breve pressione DC:
cambia modalità visualizzazione

ALIMENTAZIONE DISPOSITIVI VIA USCITA AC

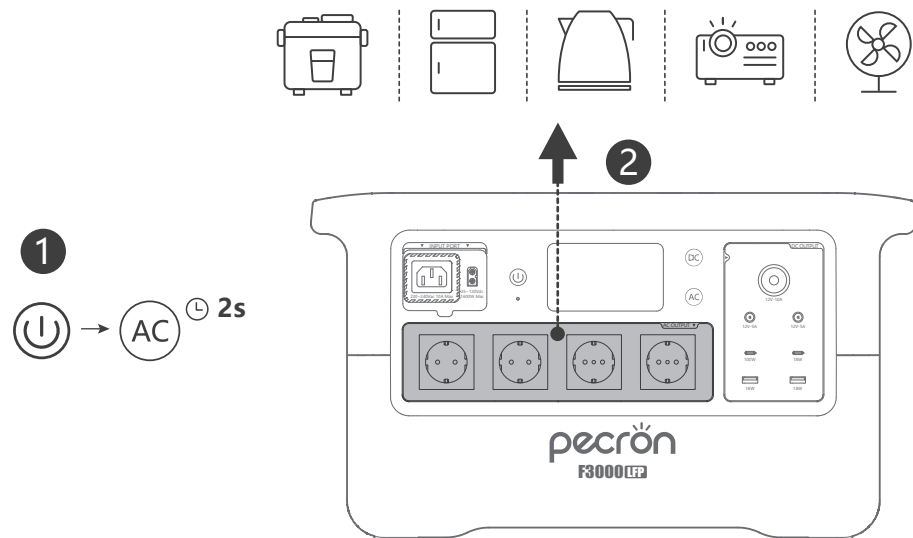

- 1: A dispositivo acceso, tenere premuto il tasto AC per attivare l'alimentazione nella zona porte corrispondente.
- 2: Collegare il dispositivo alle prese di uscita AC del prodotto.

- ⚡ 1: Durante funzionamento ad alta potenza potrebbe verificarsi un leggero odore, fenomeno normale che scompare con l'uso.
- 2: Durante la ricarica con input AC a frequenza diversa, l'alimentatore commuta automaticamente alla frequenza dell'input.

ALIMENTAZIONE DISPOSITIVI VIA USCITA DC

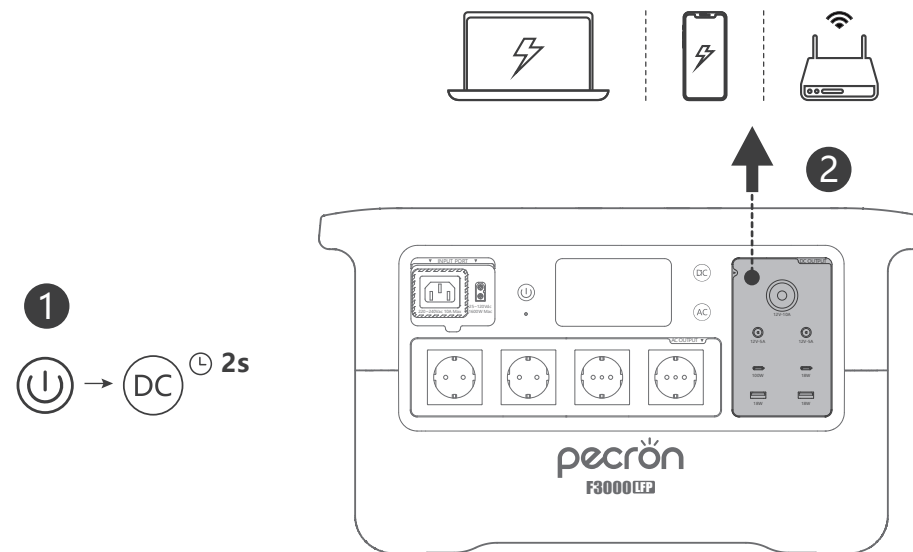

L'alimentatore supporta cavi adattatori DC (da acquistare separatamente) per soddisfare diverse esigenze di ricarica tramite le uscite DC.

RICARICA VIA AC

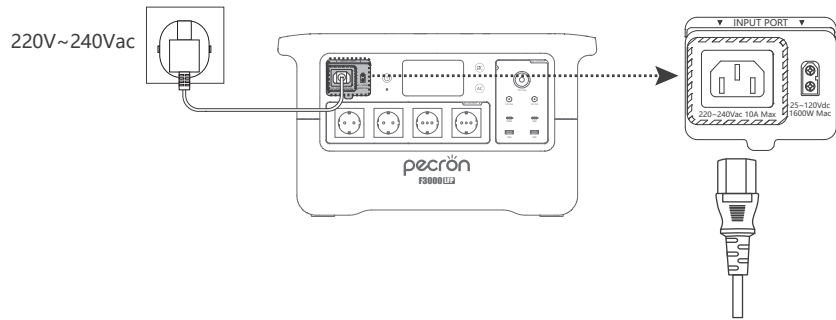

- 1: Al termine della ricarica, scollegare dalla rete elettrica.
- 2: Per prolungare la vita delle celle, evitare la scarica completa che potrebbe danneggiarle.
- 3: Se le celle sono troppo calde/fredde durante la ricarica (icona allarme lampeggiante), la potenza si riduce automaticamente per sicurezza - fenomeno normale.

FUNZIONE UPS

Il F3000 LFP supporta la funzione UPS, in grado di proteggere dispositivi (es. computer) da interruzioni di corrente quasi istantaneamente (entro 8-20ms). In modalità UPS, l'alimentatore ripristina automaticamente l'output AC. In caso di blackout con batteria esaurita, quando la corrente torna disponibile, l'alimentatore riattiverà automaticamente l'output AC per continuare a fornire energia.

Questa funzione UPS supporta solo carichi inferiori a 3600W. Si consiglia di collegare un solo dispositivo alla volta per evitare sovraccarichi.

PECRON non è responsabile per danni a dispositivi o perdita di dati causati dall'uso non conforme alle istruzioni.

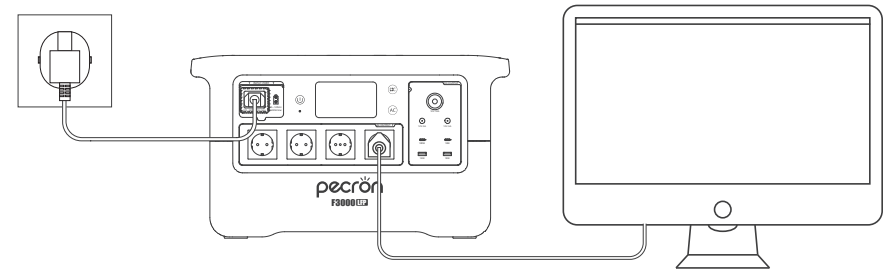

- 1: Non adatto per applicazioni critiche (es. server/workstation) che richiedono tempi di transizione inferiori a 8ms, per evitare malfunzionamenti o perdita di dati.
- 2: La funzionalità potrebbe non essere disponibile in alcune aree. Consultare le normative locali per dettagli.

RICARICARE CON PANNELLI SOLARI

Procedura:

1: Dispiegare il pannello solare e fissarlo con il supporto.

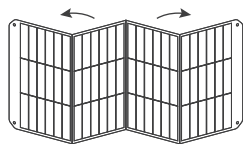

2: Regolare l'angolazione del pannello solare tramite il supporto, assicurandosi che sia rivolto direttamente verso il sole.

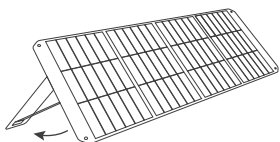

3: Per massimizzare l'efficienza, orientare il pannello in modo che i raggi solari lo colpiscano perpendicolarmente e rimuovere eventuali ostacoli.

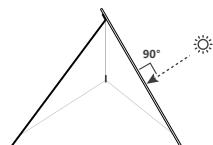

4: L'ingresso XT60 supporta una tensione di 25-120Vcc, potenza massima in ingresso di 1600W e corrente massima di 25A.

In serie, la tensione totale è la somma delle tensioni dei pannelli collegati: la tensione a circuito aperto (V_{oc}) deve essere $<120V$, e la tensione di lavoro (V_{mp}) $>25V$.

In parallelo, la corrente totale (I_{mp}) deve avvicinarsi alla corrente massima in ingresso (I_{max}) del prodotto.

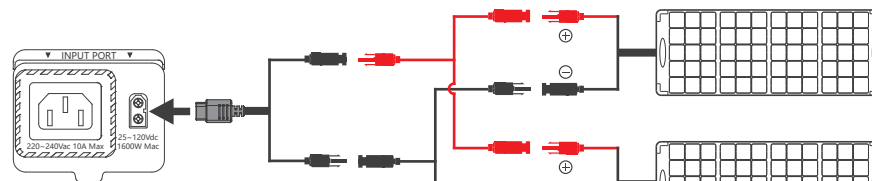
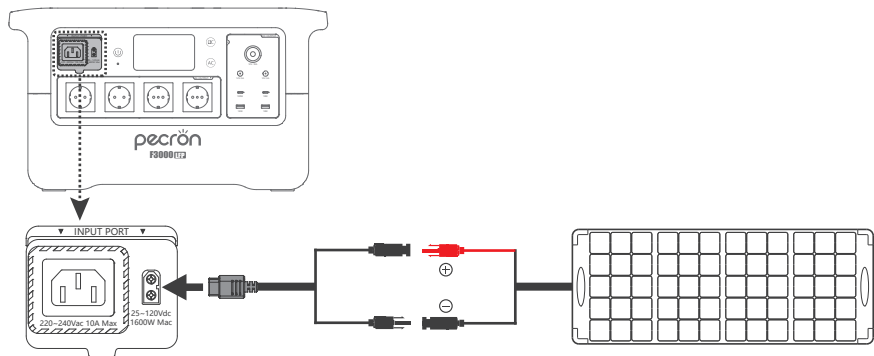

I cavi per il collegamento in parallelo devono essere acquistati separatamente.

- 1: Non utilizzare pannelli solari di tipo diverso, per evitare danni al dispositivo.
- 2: Si consigliano i pannelli PECRON per prevenire danni al modulo di adattamento e all'alimentatore.
- ⚠ 3: Durante la ricarica solare, evitare l'esposizione diretta al sole dell'alimentatore e del modulo di adattamento per prevenire surriscaldamento.
- 4: Rimuovere tempestivamente polvere o detriti dalla superficie: ombreggiature parziali riducono l'efficienza.
- 5: Pulire periodicamente il pannello con un panno morbido inumidito con acqua.

FUNZIONALITÀ DELL'APP

Con l'APP PECRON puoi connetterti al prodotto, visualizzare informazioni, controllare il dispositivo e personalizzare le impostazioni.

A dispositivo spento, tieni premuto il pulsante di accensione per 5 secondi per riavviare e attivare la modalità di abbinamento (3 minuti). L'icona Bluetooth/WIFI lampeggerà.

Gli utenti iPhone possono cercare "PECRON" sull'Apple Store per scaricare l'APP.

Gli utenti Android possono cercare "PECRON" su Google Play per il download.



⚠ Per connetterti all'APP è necessario il Wi-Fi a 2.4 GHz!

FUNZIONALITÀ PORTA ESPANSIONE BATTERIA

Utilizzando la porta XT120 sul lato destro, è possibile collegare fino a due batterie aggiuntive da 48V tramite cavo in cascata.

È vietato l'uso di batterie non PECRON, per evitare danni all'alimentatore!

Nota: per un abbinamento più rapido, la differenza di carica tra l'unità principale e le batterie aggiuntive deve essere inferiore al 10%.

La porta XT120, con cavo dedicato PECRON, può erogare una tensione di 44-58V e una corrente massima di 40A.

ELENCO PRODOTTO E ACCESSORI INCLUSI

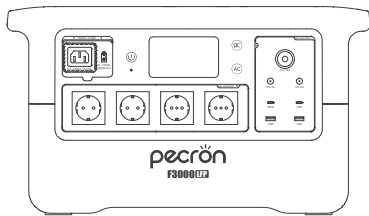

PECRON F3000 LFP *1

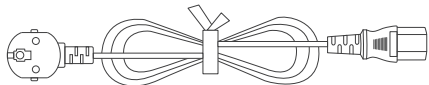

Cavo di alimentazione AC *1

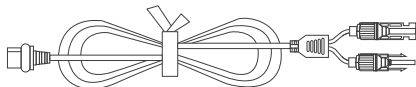

Cavo solare
adattatore XT60-MC4 *1



Bustina accessori *1

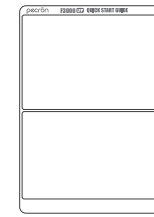

Guida rapida all'uso *1

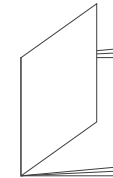

Guida utente *1

ACCESSORI OPZIONALI



PECRON EP3000-48V

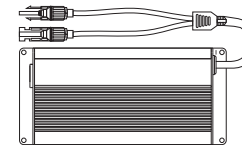

Caricabatterie auto
intelligente PECRON 500W

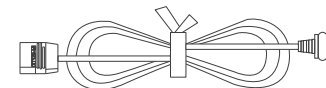

Cavo di uscita XT120 PECRON



Altri accessori disponibili
sul sito ufficiale PECRON

RISOLUZIONE PROBLEMI

Allarme sovraccarico:
lampeggia "OVERLOAD".
Segnale acustico (2 bip).

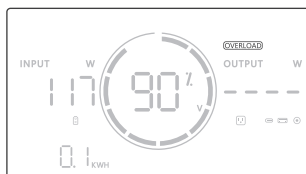

Allarme temperatura batteria:
lampeggia simbolo temperatura.
Segnale acustico (3 bip).

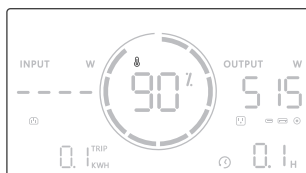

Altri allarmi:
lampeggia simbolo punto esclamativo.

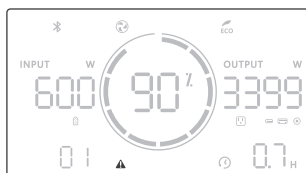

ALLARMI

- 02 Sottotensione pacco batteria
- 03 Sovracorrente scarica batteria
- 04 Sovracorrente carica batteria
- 05 Cortocircuito batteria
- 06 Interruzione cavo batteria
- 07 Carica bloccata (batteria a bassa tensione)
- 08 Temperatura carica troppo bassa
- 09 Temperatura carica troppo alta
- 10 Temperatura scarica troppo bassa
- 11 Temperatura scarica troppo alta
- 12 Anomalia modulo carica durante scarica
- 20 Sovraccarico inverter
- 21 Surriscaldamento inverter
- 22 Sotto/sovratensione bus DC
- 35 Surriscaldamento carica DC

40 Cortocircuito/sovraccarico uscita DC

41 Sovratensione uscita DC

42 Sovracorrente uscita DC

43 Surriscaldamento uscita DC

51 Sottotensione pacco supplementare

52 Sovracorrente scarica pacco supplementare

53 Sovracorrente carica pacco supplementare

54 Cortocircuito pacco supplementare

55 Interruzione cavo pacco supplementare

57 Temperatura carica troppo bassa (pacco supp.)

58 Temperatura carica troppo alta (pacco supp.)

59 Temperatura scarica troppo bassa (pacco supp.)

60 Temperatura scarica troppo alta (pacco supp.)

DOMANDE FREQUENTI

1: Quale tipo di cella utilizza F3000 LFP? Qual è la sua durata?

F3000 LFP utilizza celle LiFePO4 (litio ferro fosfato) di qualità automobilistica, certificate UL, con oltre 3500 cicli di carica/scarica completi mantenendo più dell'80% della capacità.

2: Quali dispositivi può alimentare F3000 LFP?

Può alimentare dispositivi con potenza AC inferiore a 3600W e dispositivi DC a 12V-10A.

3: F3000 LFP ha la funzione UPS?

Supporta la funzione UPS con un tempo di commutazione tra 8~20ms.

4: Come calcolare la durata di alimentazione di F3000 LFP?

Per stimare l'autonomia di F3000 LFP, considerare il carico utilizzato: Autonomia = Capacità batteria (Wh) x DoD x n ÷ (Potenza carico + Consumo interno F3000 LFP)

Nota: DoD indica la profondità di scarica. "n" è l'efficienza di conversione dell'inverter, che supera il 93%. Il consumo interno di F3000 LFP è circa 30W.

Autonomia = 3072Wh x 95% x 93% ÷ (40W + 30W) ≈ 39 ore.

Si prega di notare che l'autonomia stimata è solo a titolo indicativo e può variare in base alle condizioni d'uso reali. Temperature basse e carichi eccessivi riducono significativamente la capacità della batteria, accorciando l'autonomia media.

5: F3000 LFP può caricare e scaricare simultaneamente?

Sì, può caricare e scaricare contemporaneamente. In modalità non-UPS, per un uso continuo, la potenza media di carica deve essere superiore a quella di scarica, altrimenti la batteria si esaurirà e si spegnerà.

6: F3000 LFP ha un controller MPPT integrato?

Sì, è dotato di un controller di carica MPPT integrato indipendente, con porta "XT60" che supporta 25~120V (massimo 1600W).

7: Altre avvertenze importanti?

Il dispositivo non è impermeabile: evitare acqua e umidità.

Garantire una buona ventilazione durante l'uso, mantenendo libere le prese d'aria.

Non utilizzare in ambienti speciali (miniere, stazioni di servizio, ecc.).

MANUTENZIONE E CURA

- 1: Conservare il dispositivo in un ambiente tra -10°C (14°F) e 45°C (113°F). Si consiglia una temperatura compresa tra 0°C (32°F) e 30°C (86°F) per mantenere la batteria in buone condizioni.
- 2: Riporre il prodotto in un'area asciutta, fresca, ben ventilata e sicura per ridurre il rischio di cadute.
- 3: Assicurarsi che il dispositivo sia lontano da acqua, fonti di calore, campi magnetici forti, ambienti con gas corrosivi e qualsiasi materiale infiammabile o esplosivo.
- 4: Ricaricare completamente il dispositivo almeno una volta ogni 2 mesi. Se lasciato a lungo senza carica completa, la precisione della carica e la coerenza della batteria potrebbero peggiorare.
- 5: In caso di conservazione prolungata, eseguire un ciclo di carica e scarica ogni 3 mesi (carica completa, poi scarica fino al 60% prima di riporlo) per mantenere la batteria in salute.
- 6: Non lasciare il dispositivo inutilizzato o senza carica per più di 6 mesi, altrimenti la garanzia verrà invalidata.
- 7: Se la porta di ricarica è sporca, pulirla con un panno asciutto. Non utilizzare alcol o altri agenti infiammabili per la pulizia.

DICHIARAZIONE DI NON RESPONSABILITÀ

Prima dell'uso, leggere il manuale utente di questo prodotto per garantire un utilizzo corretto dopo averne compreso appieno il contenuto. Dopo la lettura, conservare il manuale per future consultazioni. Un utilizzo improprio del prodotto potrebbe causare gravi danni a sé stessi o ad altri, nonché danni al prodotto e perdite materiali. L'uso del prodotto implica la piena comprensione, accettazione e approvazione di tutti i termini e contenuti del presente documento. L'utilizzatore si assume ogni responsabilità per le proprie azioni e le relative conseguenze. La società non sarà ritenuta responsabile per eventuali danni derivanti dall'uso del prodotto non conforme al presente documento o al manuale utente.

Nel rispetto delle leggi e dei regolamenti, la società si riserva il diritto di interpretazione finale del presente documento e di tutta la documentazione correlata al prodotto. Aggiornamenti, revisioni o interruzioni potranno avvenire senza preavviso. Si prega di consultare il sito ufficiale PECRON per le informazioni più recenti sul prodotto.

UTILIZZO

- 1: È severamente vietato avvicinare il prodotto a fonti di calore, come fiamme libere o stufe, durante il funzionamento.
- 2: È assolutamente vietato esporre il prodotto a liquidi. Non immergerlo in acqua o bagnarlo. Non utilizzare il prodotto sotto la pioggia o in ambienti umidi.
- 3: Vietato utilizzare il prodotto in ambienti con forti cariche elettrostatiche o campi magnetici intensi.
- 4: È vietato smontare il prodotto in alcun modo o perforarlo con oggetti appuntiti.
- 5: Non causare cortocircuiti al prodotto utilizzando fili o altri oggetti metallici.
- 6: Non utilizzare il prodotto per avviare direttamente l'auto. È destinato esclusivamente alla ricarica della batteria dell'automobile.
- 7: Non utilizzare componenti o accessori non ufficiali. Per eventuali sostituzioni, consultare i canali di vendita ufficiali PECRON per informazioni sugli acquisti.
- 8: Durante l'uso, rispettare rigorosamente l'intervallo di temperatura ambientale specificato nel manuale. Temperature troppo elevate possono causare incendi o esplosioni della batteria; temperature troppo basse riducono drasticamente le prestazioni, rendendo il prodotto inutilizzabile.
- 9: Non posizionare oggetti pesanti sopra il prodotto.

- 10: Non ostruire forzatamente la ventola durante l'uso o collocare il prodotto in spazi non ventilati o polverosi.
- 11: Evitare urti, cadute o vibrazioni intense. In caso di impatto violento, spegnere immediatamente il dispositivo e interrompere l'uso. Durante il trasporto, fissare saldamente per evitare scossoni e urti.
- 12: Se il prodotto cade accidentalmente in acqua, posizionarlo in un'area aperta e sicura, mantenendo la distanza fino al completo asciugamento. Non riutilizzare il prodotto asciugato: smaltirlo secondo le istruzioni del capitolo "Smaltimento". In caso di incendio, utilizzare estintori in quest'ordine preferenziale: acqua/nebbia d'acqua, sabbia, coperta antifiama, polvere estinguente, estintore a CO2.
- 13: Pulire le porte del prodotto con un panno asciutto se sporche.
- 14: Posizionare il prodotto con cura per evitare ribaltamenti e danni. In caso di caduta con danni gravi, spegnerlo immediatamente, isolare la batteria in un'area aperta lontano da materiali infiammabili e persone, e smaltirlo secondo le normative locali.
- 15: Conservare il prodotto fuori dalla portata di bambini e animali domestici.

SMALTIMENTO

- 1: Se possibile, scaricare completamente la batteria del prodotto prima di smaltirlo negli appositi contenitori per il riciclo delle batterie. Questo prodotto contiene batterie, classificate come sostanze pericolose: è vietato gettarle nei rifiuti comuni. Per i dettagli, attenersi alle normative locali sul riciclo e lo smaltimento delle batterie.
- 2: Se un guasto del prodotto impedisce lo scaricamento completo della batteria, non smaltirla nei contenitori per il riciclo. Contattare un'azienda specializzata nello smaltimento batterie per ulteriori trattamenti.
- 3: Una batteria eccessivamente scaricata non può essere riavviata: procedere con lo smaltimento secondo le norme.

ESCLUSIONI DALLA GARANZIA

La garanzia PECRON non si applica nei seguenti casi:
uso improprio, abuso, modifiche, danni accidentali o utilizzo diverso da quello previsto per il normale consumo.